



poweredbycisco.
networkers
2005

CAMPUS DESIGN: ANALYZING THE IMPACT OF EMERGING TECHNOLOGIES ON CAMPUS DESIGN

SESSION RST-3479

Campus Design

A Multitude of Design Options and Challenges

Cisco.com

- Campus network design is evolving in response to multiple drivers
- Voice, financial systems driving requirement for 5 nines availability and minimal convergence times
- Adoption of Advanced Technologies (voice, segmentation, security, wireless) all introduce specific requirements and changes
- The Campus is an integrated system everything impacts everything else

**High Availability Combined
with Flexibility and Reduced OPEX**

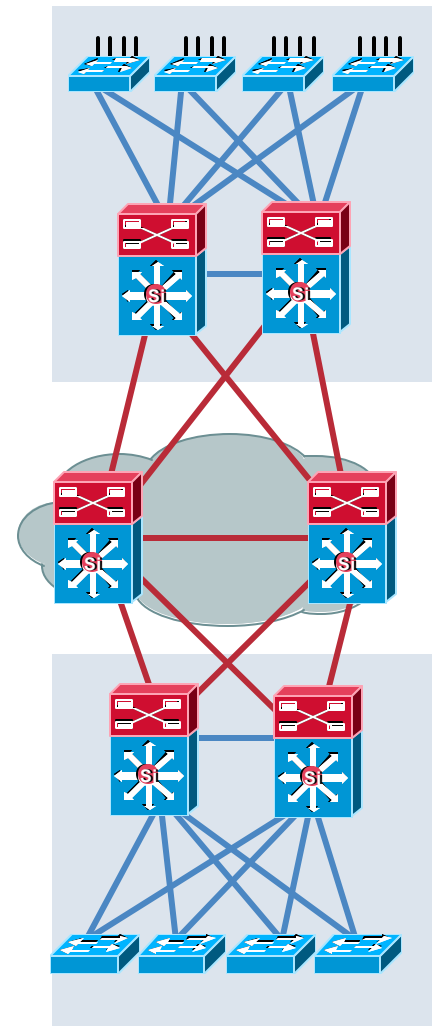

Agenda

- **Foundational Design Review**
- **Convergence—IP Communications**
- **Wireless LAN and Wireless Mobility**
- **High Availability**
 - Alternatives to STP
 - Device HA (NSF/SSO and Stackwise™)
 - Resilient Network Design
- **Segmentation and Virtualization**
 - Access Control (IBNS and NAC)
 - Segmentation
- **Questions and Answers**

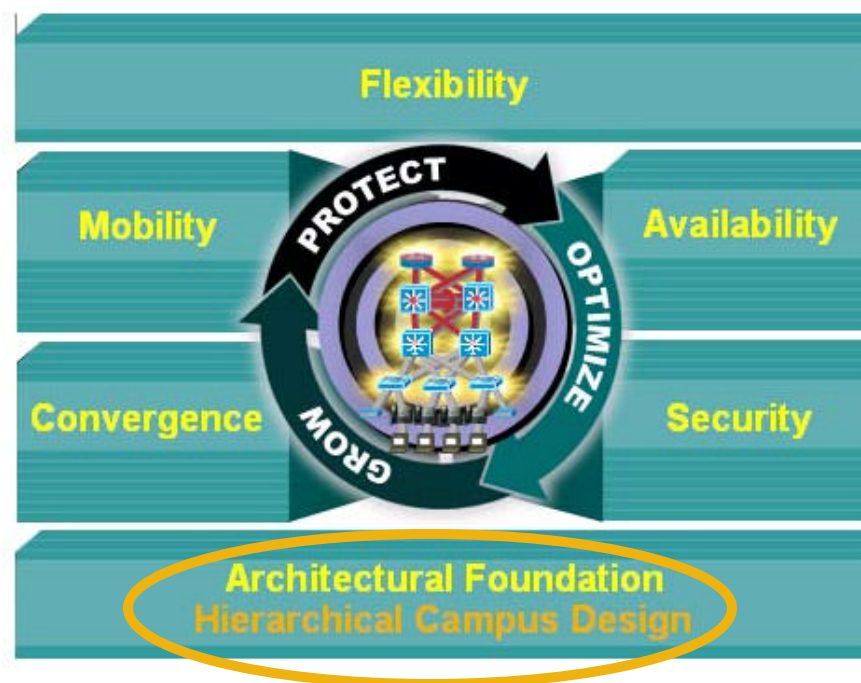

Multilayer Campus Design

Hierarchical Building Blocks

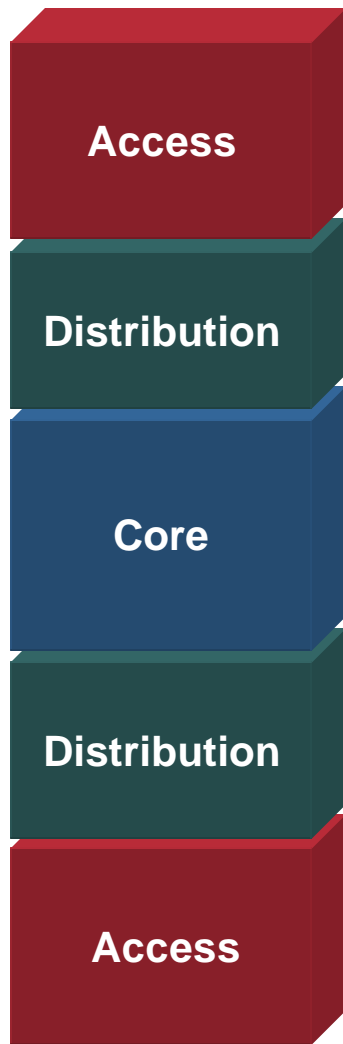

- Network trust boundary
- Use Rapid PVST+ if you MUST have L2 loops in your topology
- Use UDLD to protect against 1 way up/up connections
- Avoid daisy chaining access switches
- Avoid asymmetric routing and unicast flooding, don't span VLANS across the access layer

- Aggregation and policy enforcement
- Use HSRP or GLBP for default gateway protection
- Use Rapid PVST+ if you MUST have L2 loops in your topology
- Keep your redundancy simple; deterministic behavior = Understanding failure scenarios and why each link is needed

- Highly available and fast—always on
- Deploy QoS end-to-end: Protect the good and Punish the bad
- Equal cost core links provide for best convergence
- Optimize CEF for best utilization of redundant L3 paths

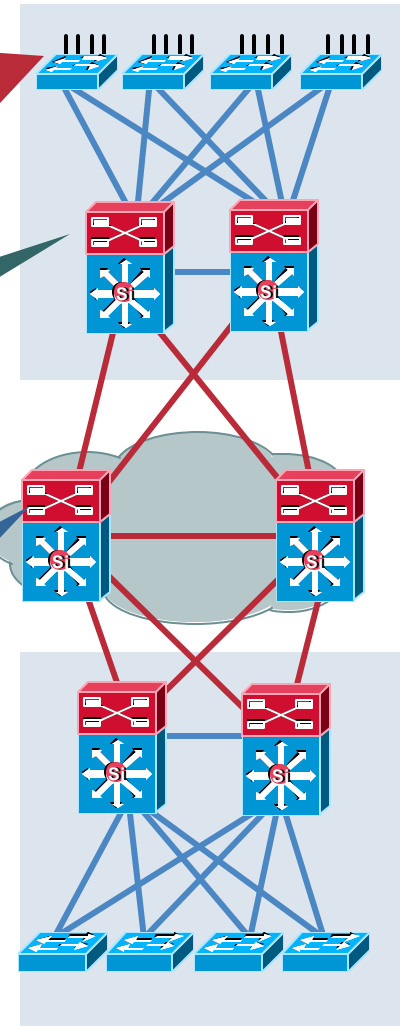

Distribution Building Block

Reference Design—No VLANs Span Access Layer

Cisco.com

- Unique Voice and Data VLAN in every access switch
- STP root and HSRP primary tuning or GLBP to load balance on uplinks
- Set Port Host on access layer ports:
 - Disable Trunking
 - Disable Etherchannel
 - Enable PortFast
- Configure Spanning Tree Toolkit
 - Loopguard
 - Rootguard
 - BPDU-Guard
- Use Cisco® Integrated Security Features (CISF) Features

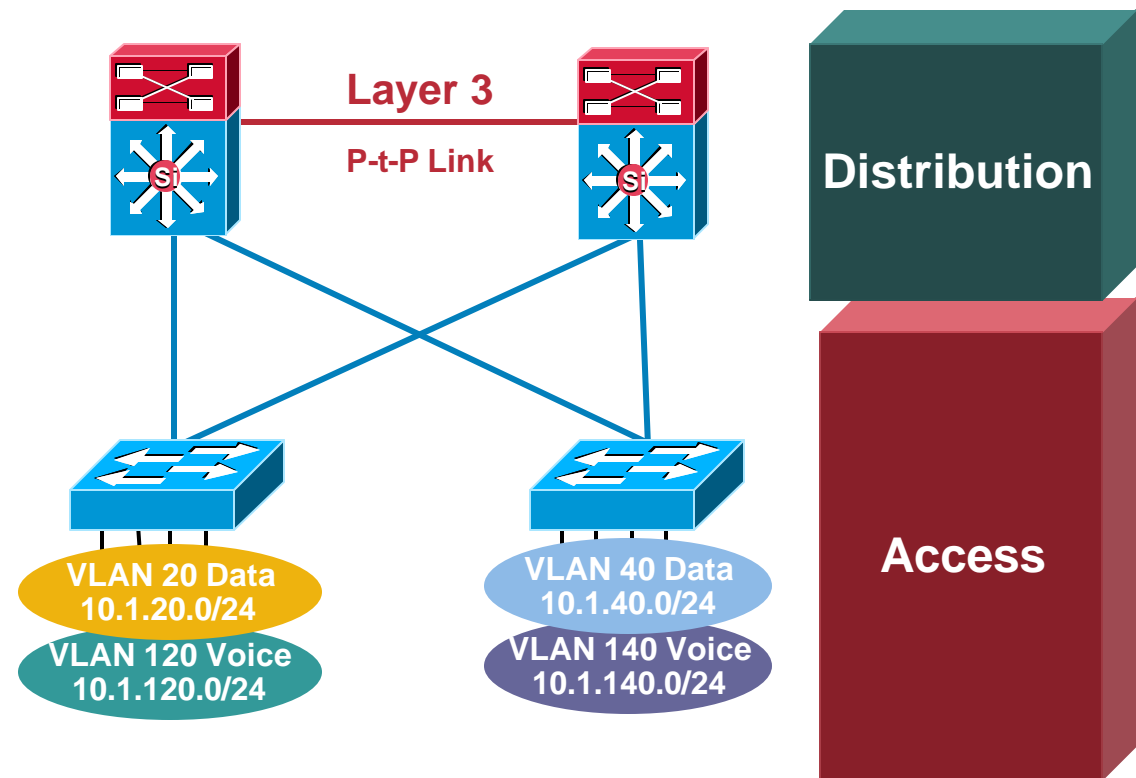

Campus Solution Test Bed

Verified Design Recommendations

Total of 68 Access Switches,
2950, 2970, 3550, 3560, 3750,
4507 SupII+, 4507 SupIV, 6500
Sup2, 6500 Sup32, 6500 Sup720
and 40 APs (1200)

Three Distribution Blocks
6500 with Redundant Sup720
4507 with Redundant SupV

6500 with Redundant Sup720s

Three Distribution Blocks
6500 with Redundant Sup720s
7206VXR NPEG1

4500 SupII+, 6500 Sup720,
FWSM, WLSM, IDSM2, MWAM

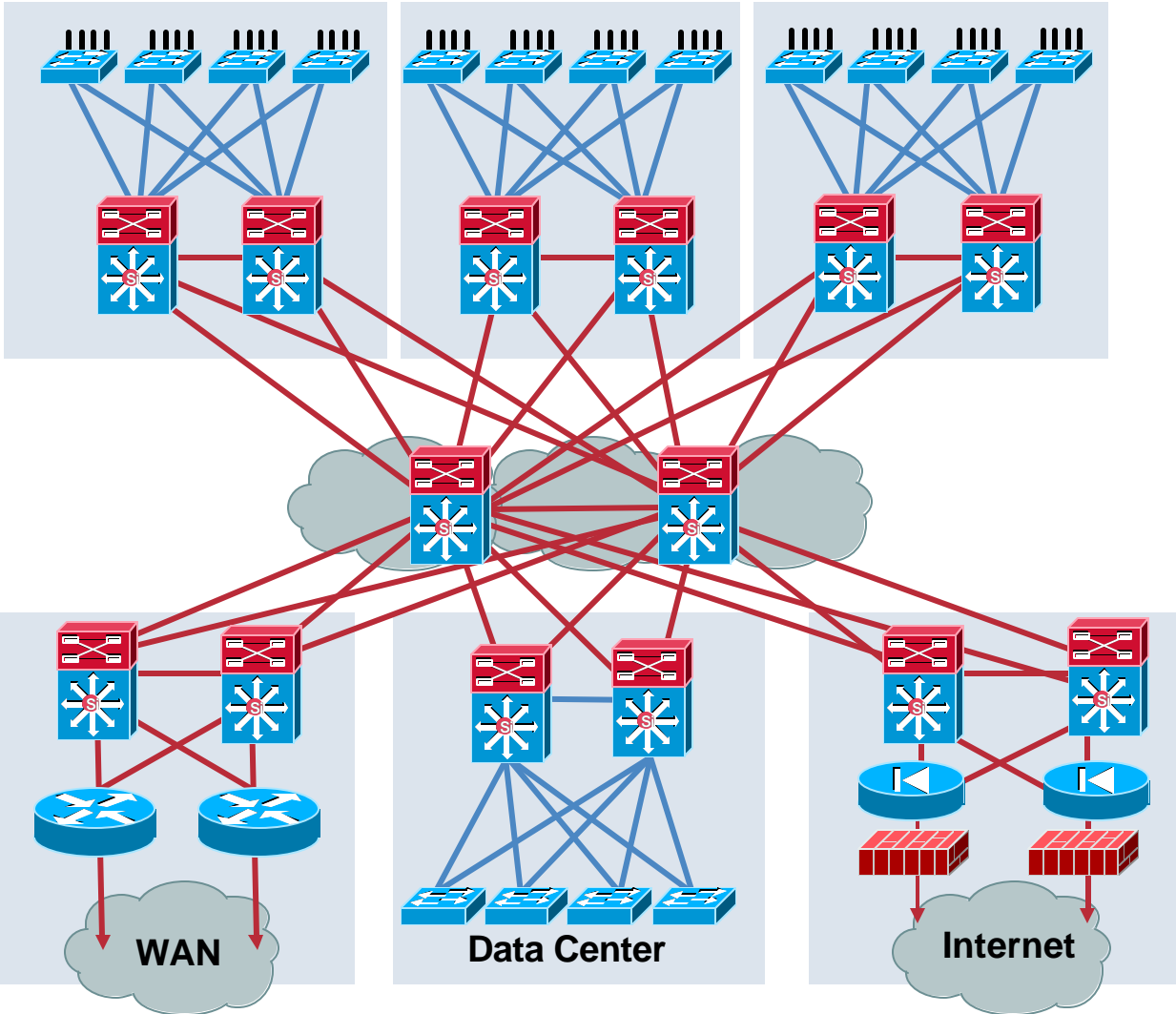

Agenda

- Foundational Design Review
- **Convergence—IP Communications**
- Wireless LAN and Wireless Mobility
- High Availability
 - Alternatives to STP
 - Device HA (NSF/SSO and Stackwise)
 - Resilient Network Design
- Segmentation and Virtualization
 - Access Control (IBNS and NAC)
 - Segmentation
- Questions and Answers

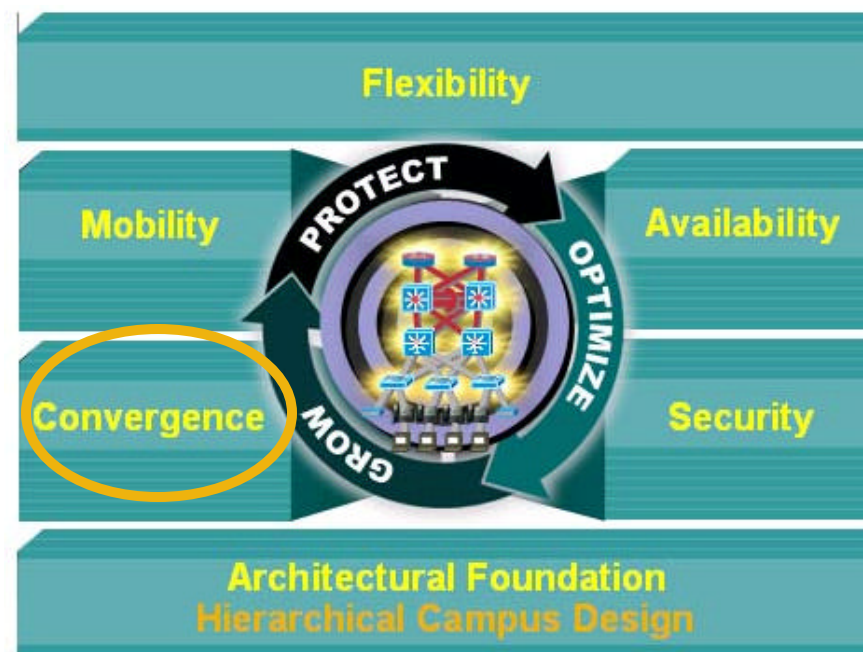

Building a Converged Campus Network

Infrastructure Integration, QoS and Availability

- Access layer**
 - Auto phone detection
 - Inline power
 - QoS: scheduling, trust boundary and classification
 - Fast convergence
- Distribution layer**
 - High availability, redundancy, fast convergence
 - Policy enforcement
 - QoS: scheduling, trust boundary and classification
- Core**
 - High availability, redundancy, fast convergence
 - QoS: scheduling, trust boundary

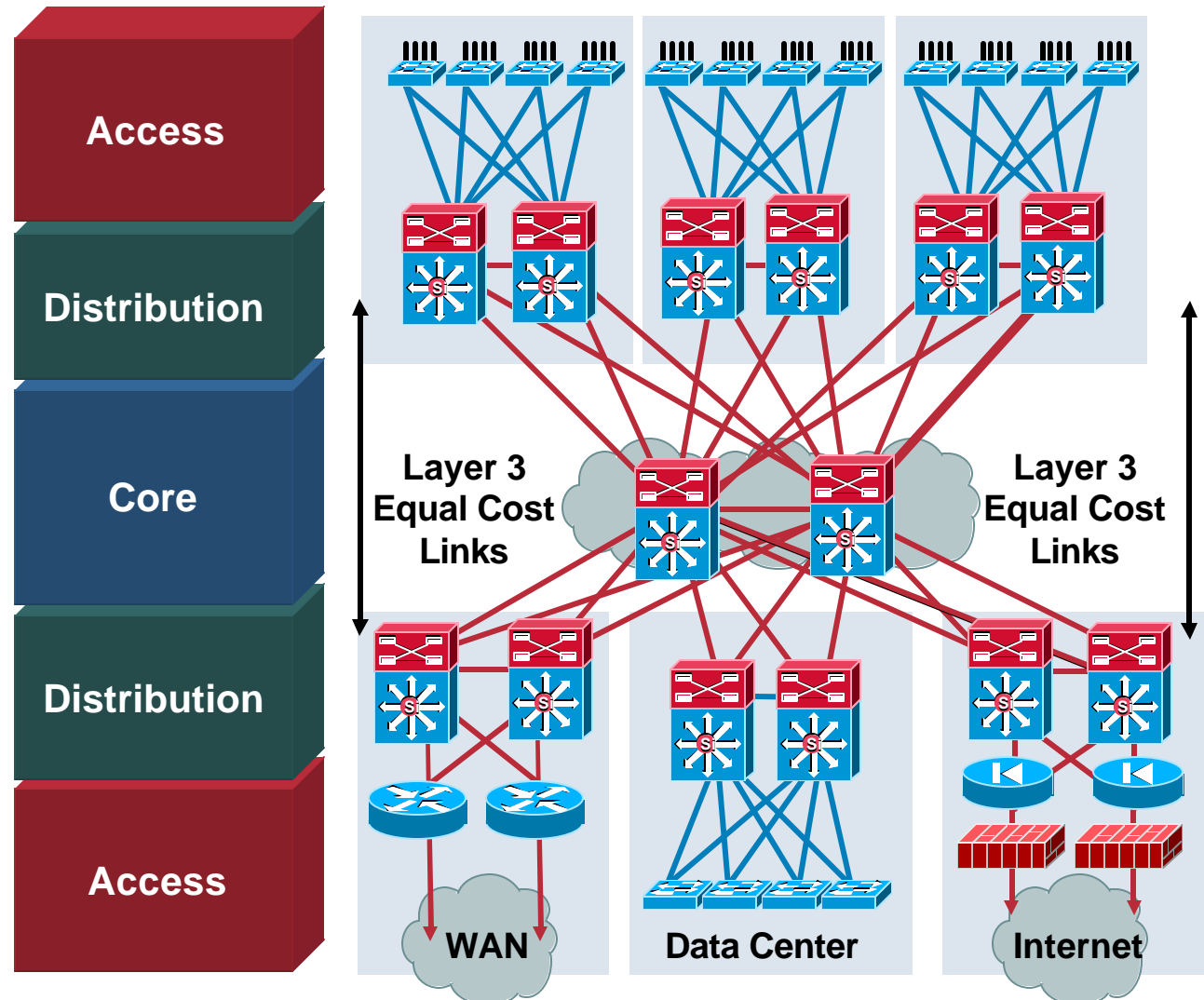

Infrastructure Integration

Extending the Network Edge

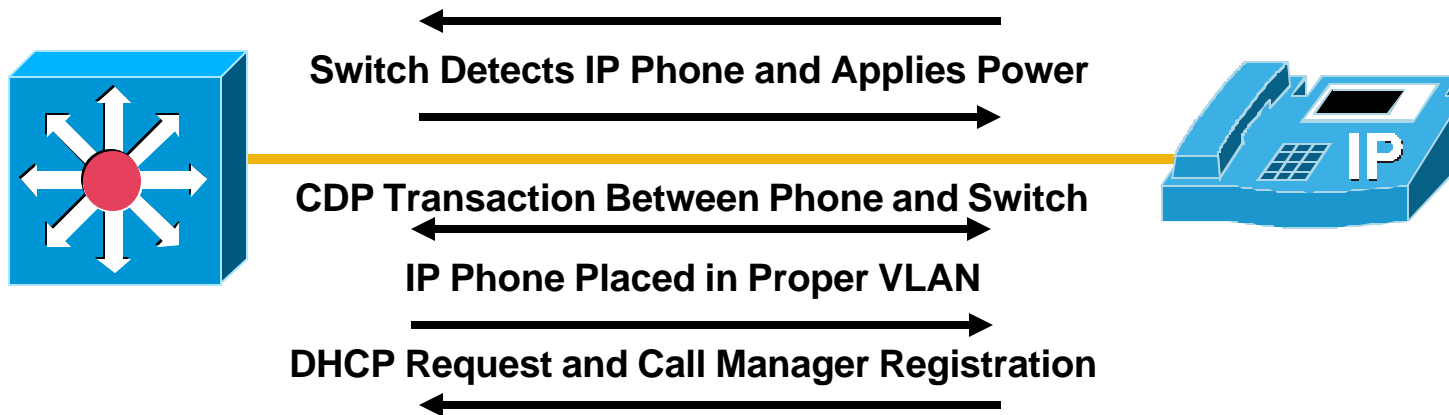

- **Phone contains a 3 port switch that is configured in conjunction with the access switch and CallManager**
 1. Power negotiation
 2. VLAN configuration
 3. 802.1x interoperation
 4. QoS configuration
 5. DHCP and CallManager registration

Infrastructure Integration: First Step

Device Detection

Pre-Standard Switch Port

Pre-Standard PoE Device (PD)

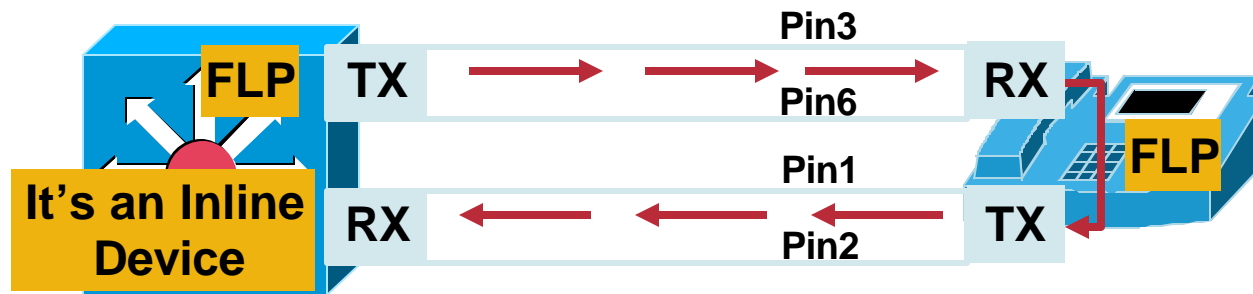

Cisco Pre-Standard Uses a Relay in PD to Reflect a Special FastLink Pulse to Detect Device

IEEE 802.3af PSE

IEEE 802.3af PD

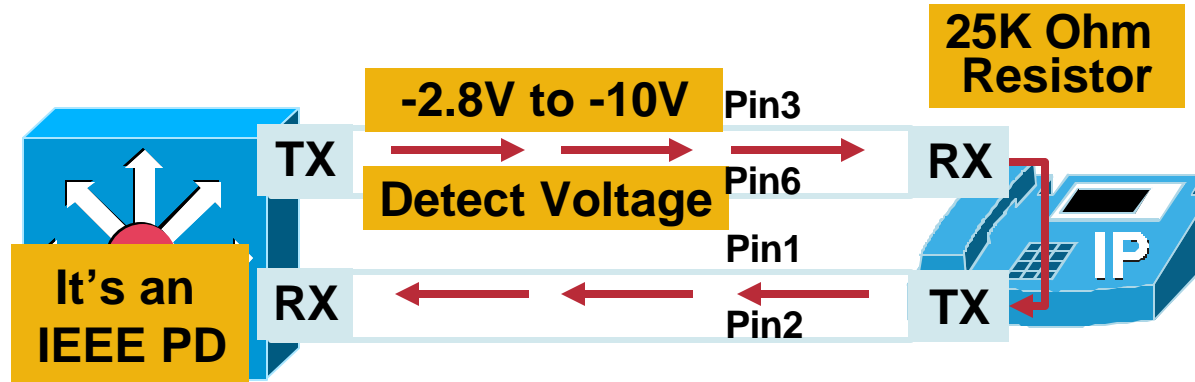

802.3af Applies a Voltage in the Range of -2.8V to -10V on the Cable and Then Looks for a 25K Ohm Signature Resistor

Infrastructure Integration: First Step

Power Requirement Negotiation

- Cisco pre-standard devices initially receive 6.3 watts and then optionally negotiate via CDP
- 802.3af devices initially receive 12.95 watts unless PSE able to detect specific PD power classification

Class	Usage	Minimum Power Levels Output at the PSE	Maximum Power Levels at the Powered Device
0	Default	15.4W	0.44 to 12.95W
1	Optional	4.0W	0.44 to 3.84W
2	Optional	7.0W	3.84 to 6.49W
3	Optional	15.4W	6.49 to 12.95W
4	Reserved for Future Use	Treat as Class 0	Reserved for Future Use: a Class 4 Signature Cannot Be Provided by a Compliant Powered Device

Enhanced Power Negotiation

802.3af Plus Bi-Directional CDP (Cisco 7970)

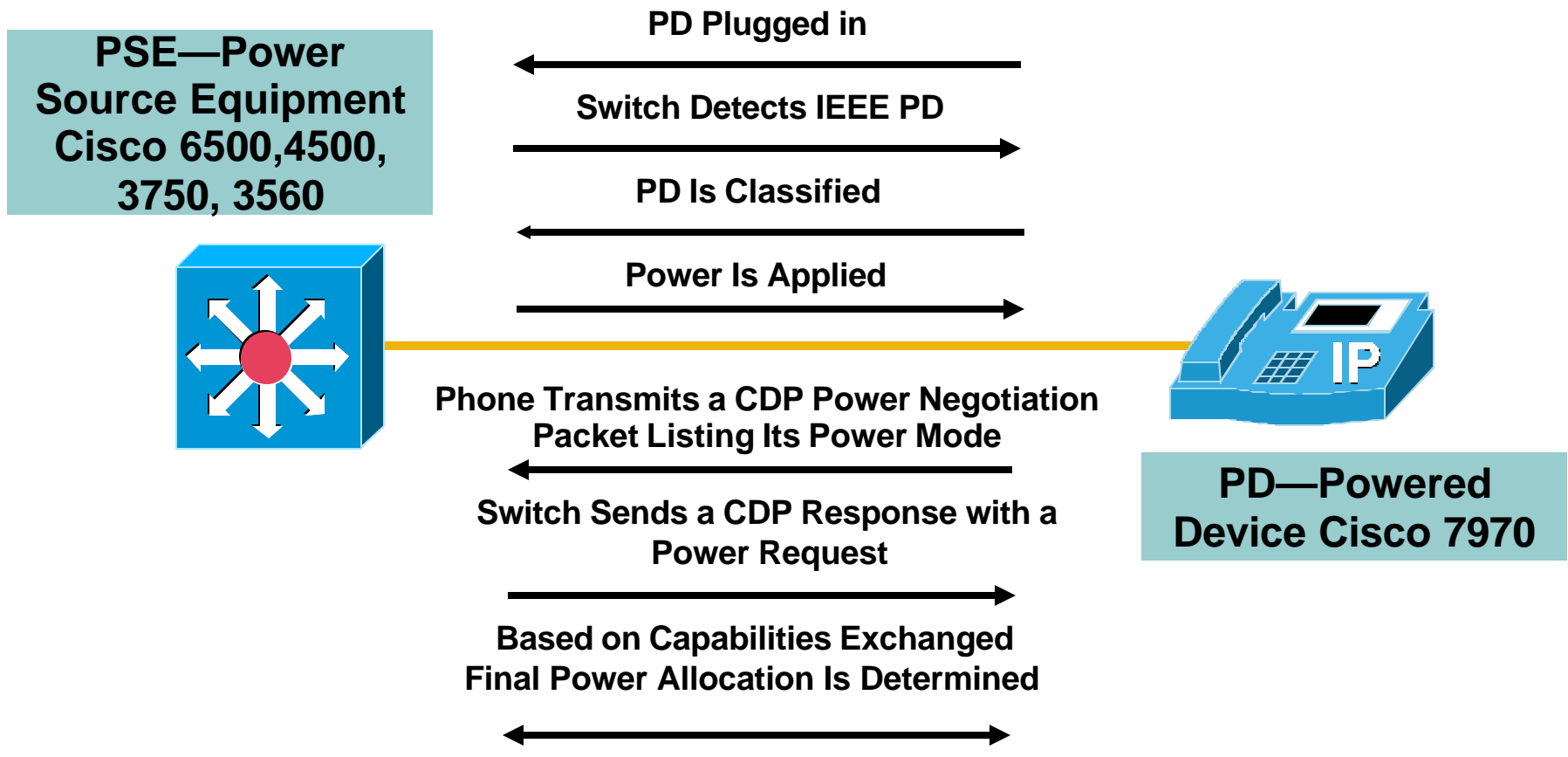

- Using bidirectional CDP exchange exact power requirements are negotiated after initial power-on

Design Considerations for PoE

Power Management

- Switch manages power by what is allocated not by what is currently used
- Device power consumption is not constant
- A 7960G requires 7W when the phone is ringing at maximum volume and requires 5W on or off hook
- Understand the power behaviour of your PoE devices
- Utilize static power configuration with *caution*

```
Dynamic allocation:  
power inline auto max 7200
```

```
Static allocation:  
power inline static max 7200
```

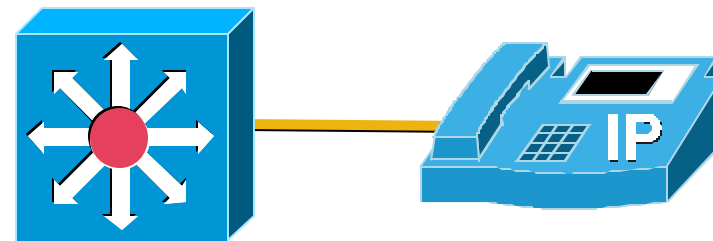

- Use power calculator to determine power requirements

<http://www.cisco.com/go/powercalculator>

Infrastructure Integration: Next Steps

VLAN, QoS and 802.1x Configuration

Cisco.com

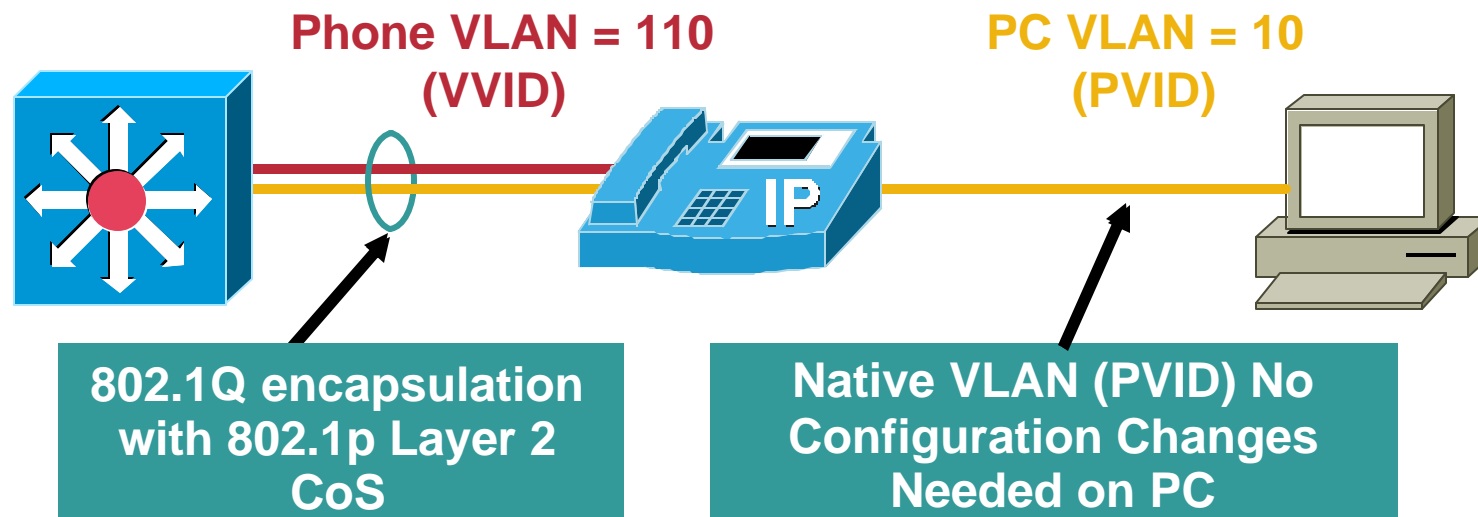

- During initial CDP exchange phone is configured with a Voice VLAN ID (VVID)
- Phone also supplied with QoS configuration via CDP TLV fields
- Additionally switch port currently bypasses 802.1x authentication for VVID if detects Cisco phone

Why QoS in the Campus

Protect the Good and Punish the Bad

Cisco.com

- QoS does more than just protect Voice and Video
- For "best-effort" traffic an implied "good faith" commitment that there are at least some network resources available is assumed
- Need to identify and potentially punish out of profile traffic (potential worms, DDOS, etc.)
- Scavenger class is an Internet-2 Draft Specification => CS1/CoS1

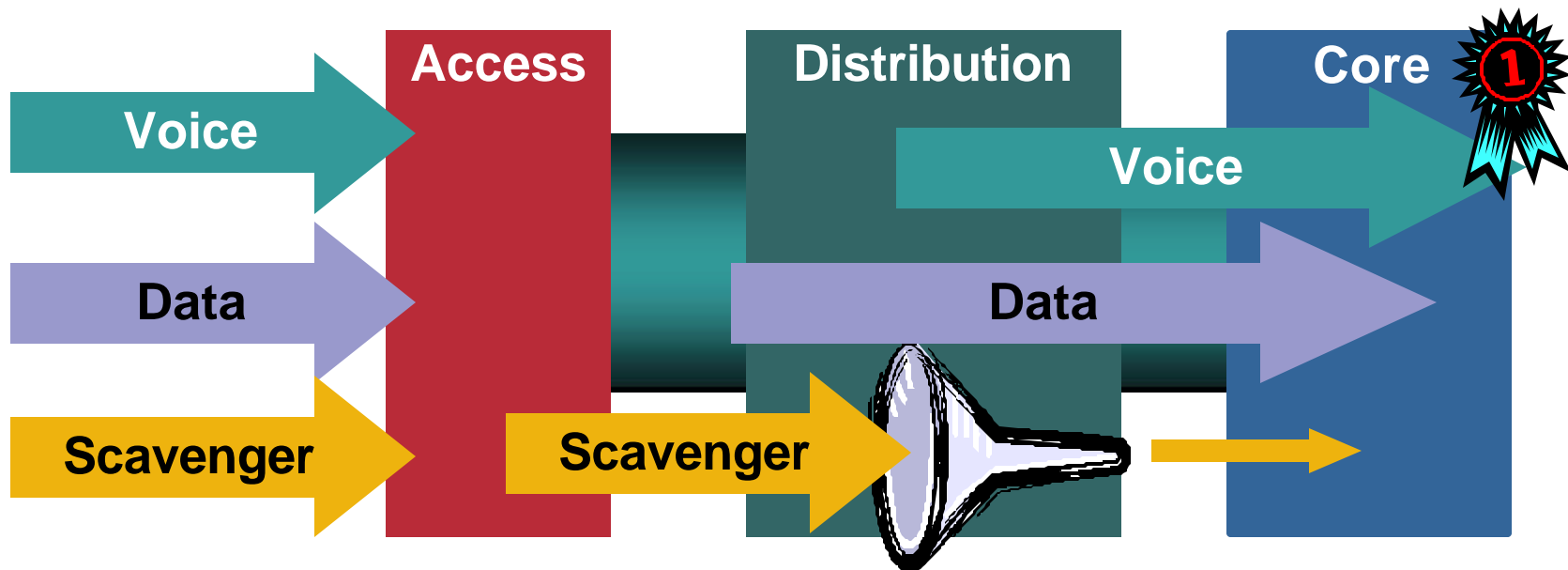

Campus QoS Design Considerations

Classification and Scheduling in the Campus

- Edge traffic classification scheme is mapped to upstream queue configuration
- Voice needs to be assigned to the HW priority queue
- Scavenger traffic needs to be assigned its own queue/threshold
- Scavenger configured with low threshold to trigger aggressive drops
- **Multiple queues are the only way to “guarantee” voice quality, protect mission critical and throttle abnormal sources**

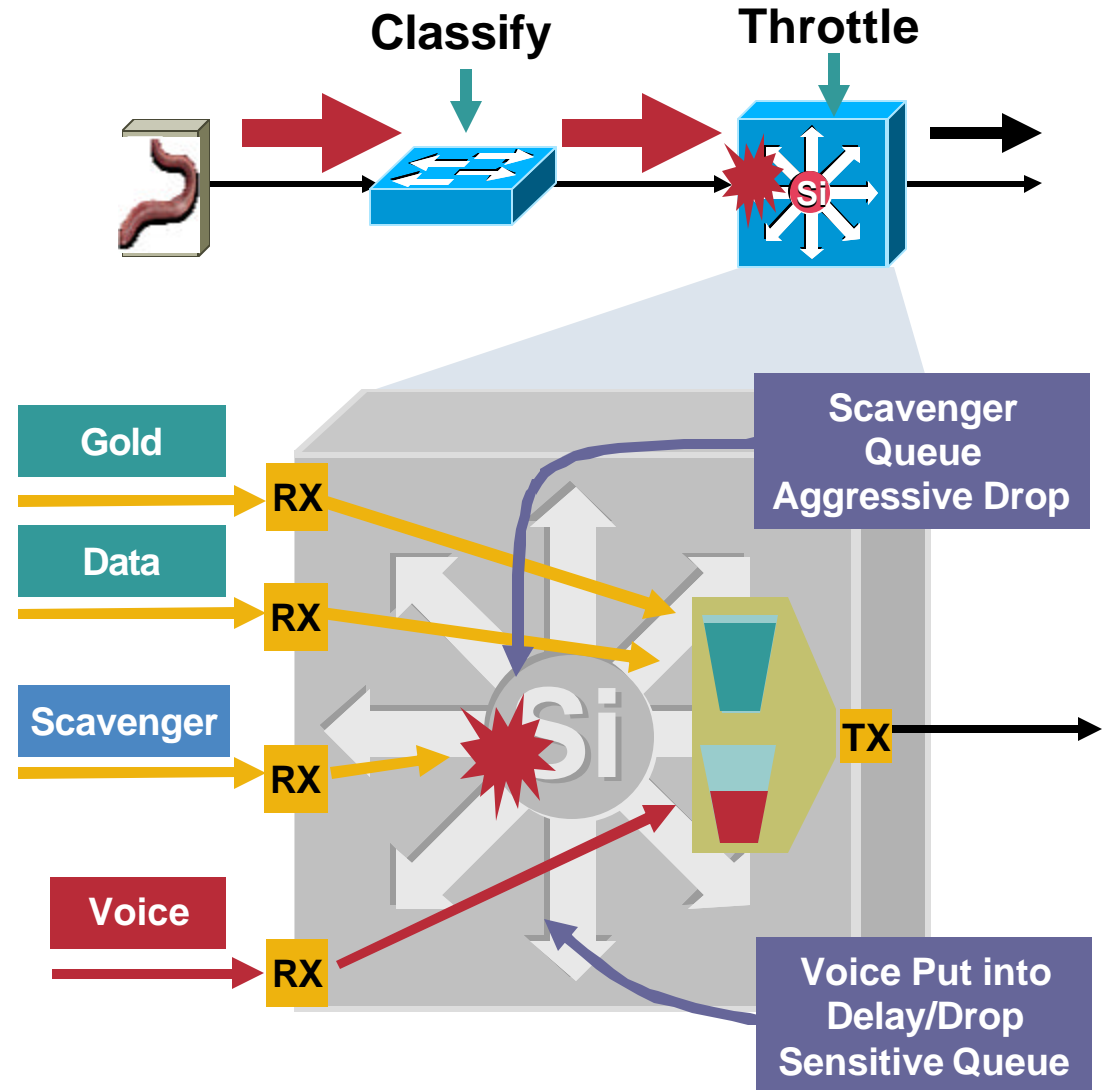

Agenda

- Foundational Design Review
- Convergence—IP Communications
- **Wireless LAN and Wireless Mobility**
- High Availability
 - Alternatives to STP
 - Device HA (NSF/SSO and Stackwise)
 - Resilient Network Design
- Segmentation and Virtualization
 - Access Control (IBNS and NAC)
 - Segmentation
- Questions and Answers

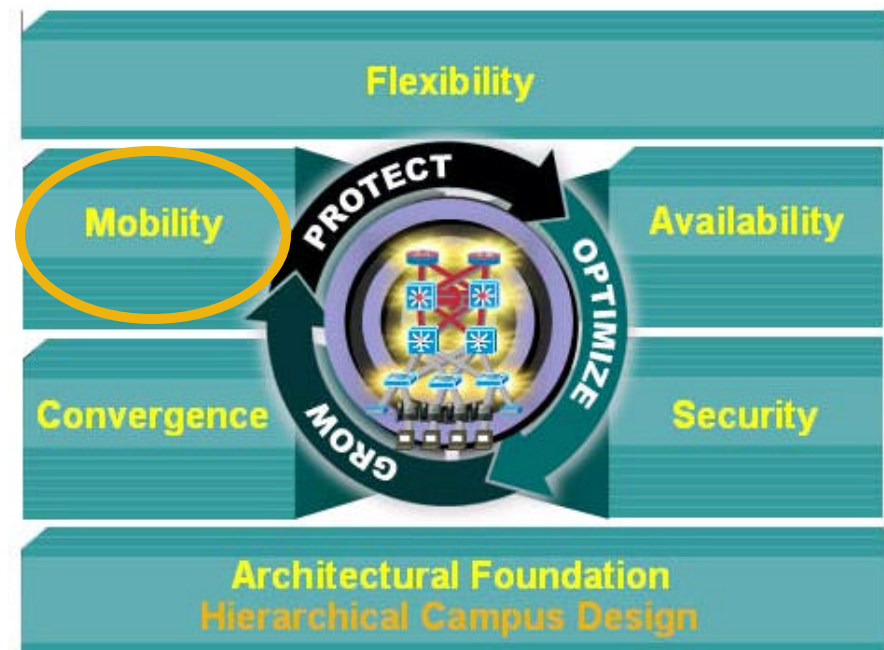

Wireless Integration into the Campus

Non-Controller-Based Wireless

Cisco.com

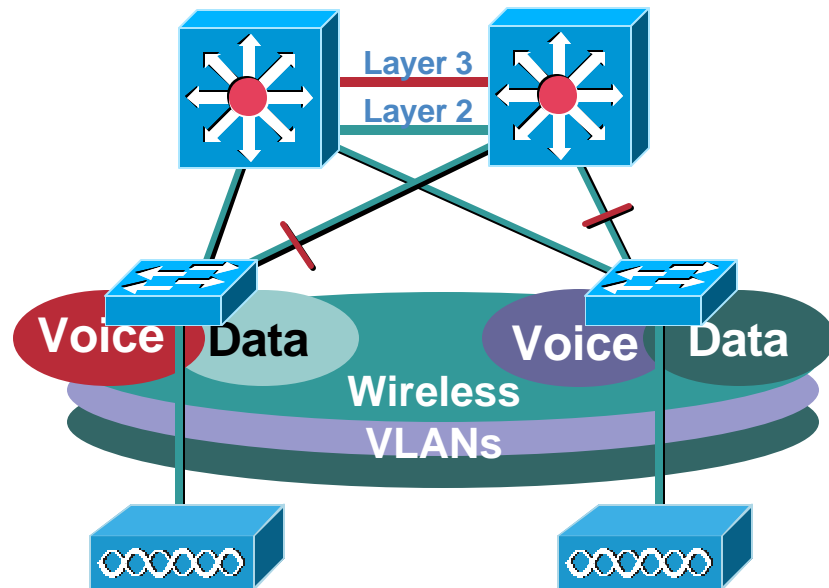

- Use a 802.1Q trunk for switch to AP connection
- Different WLAN authentication/encryption methods require new/distinct VLANs
- Layer-2 roaming requires spanning at least 2 VLANs between wiring closet switches
 1. Common 'Trunk' or native VLAN for APs to communicate to WDS
 2. The Wireless Voice VLAN

Controller-Based WLAN

The Architectural Shift

WLSM/WDS

Controller

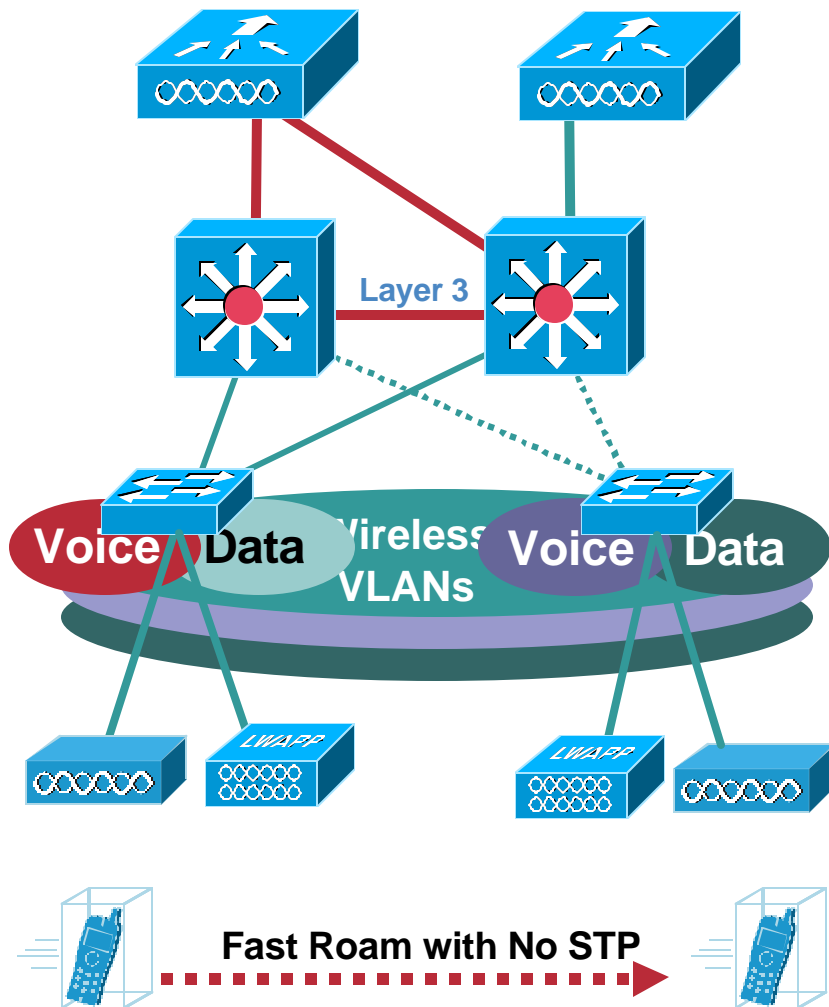

- Wireless LAN Switching Module (WLSM) provides a virtualized centralized Layer 2 domain for each WLAN
- Cisco wireless controller provides for a centralized point to bridge all traffic into the Campus
- AP VLANs are local to the access switch
- No longer a need to span a VLAN between closets
- No spanning tree loops

Wireless LAN Switching Module (WLSM) Traffic Flows

Cisco.com

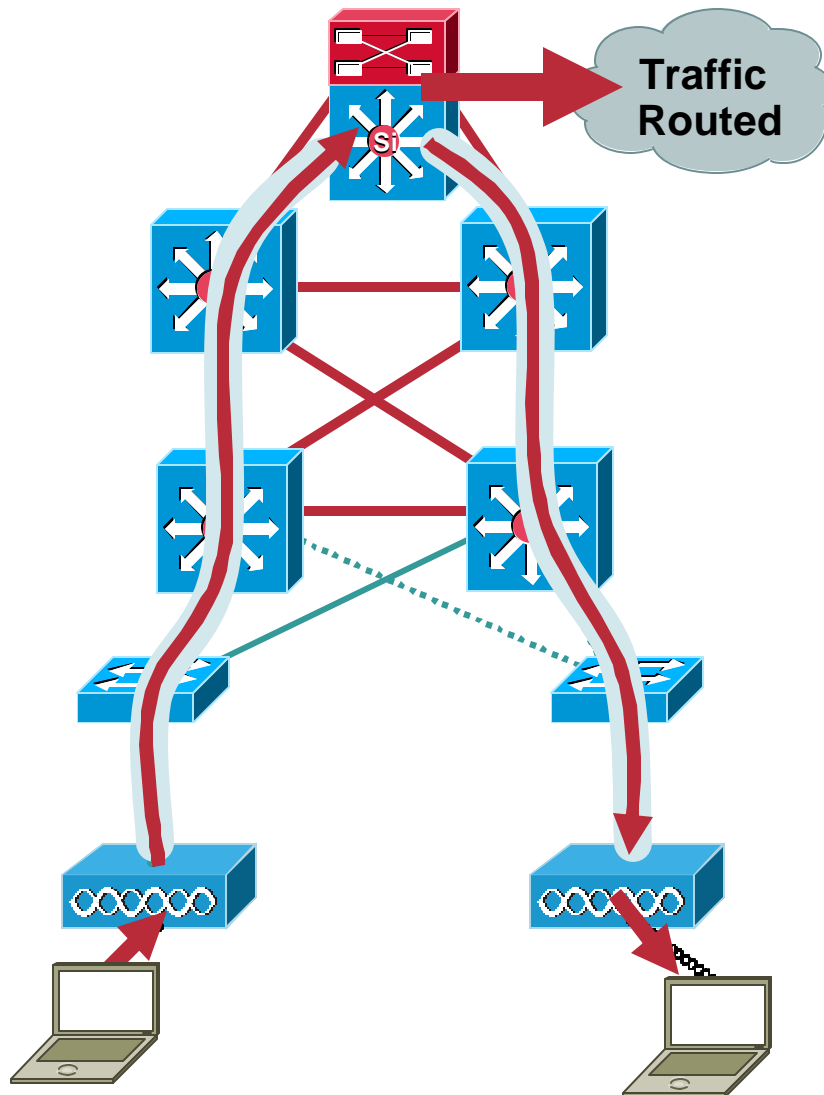

- All traffic from mobile user 1 to mobile user 2 will traverse the **GRE** tunnel to the Sup720
- Sup720 forwards de-encapsulated packets in HW
- The packet is switched and sent back to the GRE tunnel connected to other AP
- **When mobile nodes associate to the same AP traffic still flows via the WSLM/Sup720**
- Broadcast traffic either proxied by AP (ARPs) or forwarded to Sup720 (DHCP)
- Traffic to non-APs is routed to the rest of the network

Cisco Wireless Controller

Traffic Flows

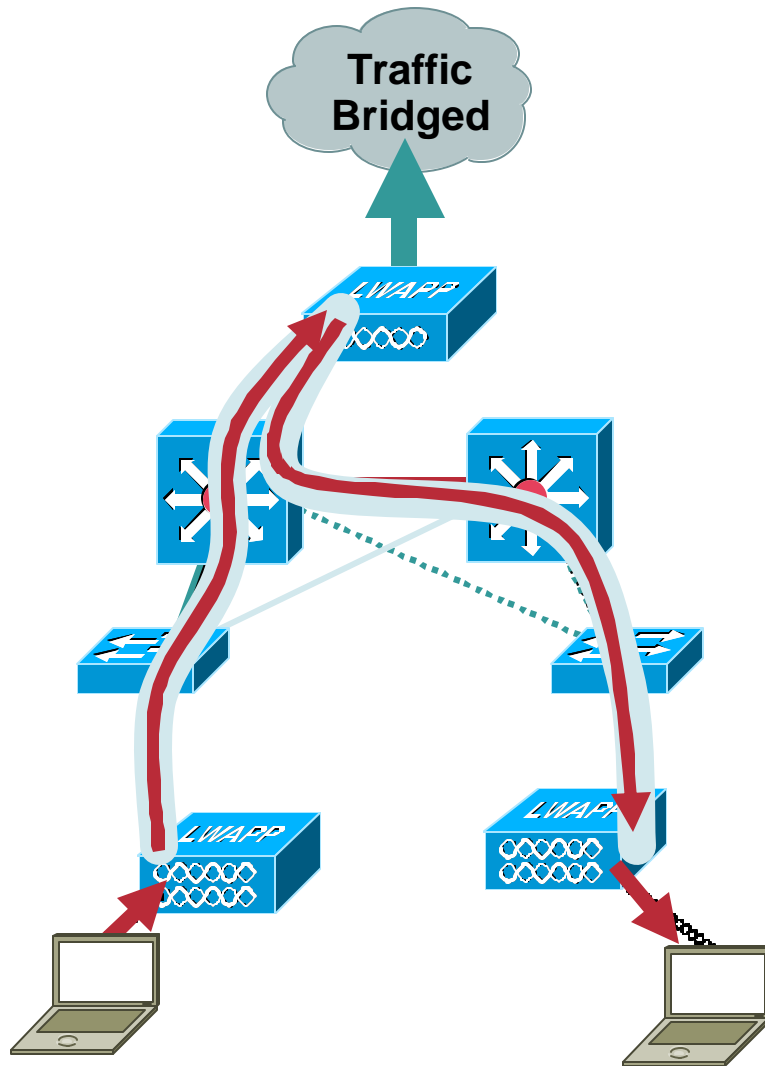

- Data is tunneled to the Controller in Light Weight Access Point Protocol (LWAPP) transport layer
- AP and Controller operate in “Split-MAC” mode dividing the 802.11 functions
- **The packet bridged onto the wired network uses the MAC address of the original wireless frame**
- Layer 2 LWAPP is in an Ethernet frame (Ethertype 0xB BBB)
- Layer 3 LWAPP is in a UDP / IP frame

Control traffic uses source port 1024 and destination port 12223

Data traffic uses source port 1024 and destination 12222

The Architectural Shift: WLSM

Network-ID Replaces the “VLAN”

Cisco.com

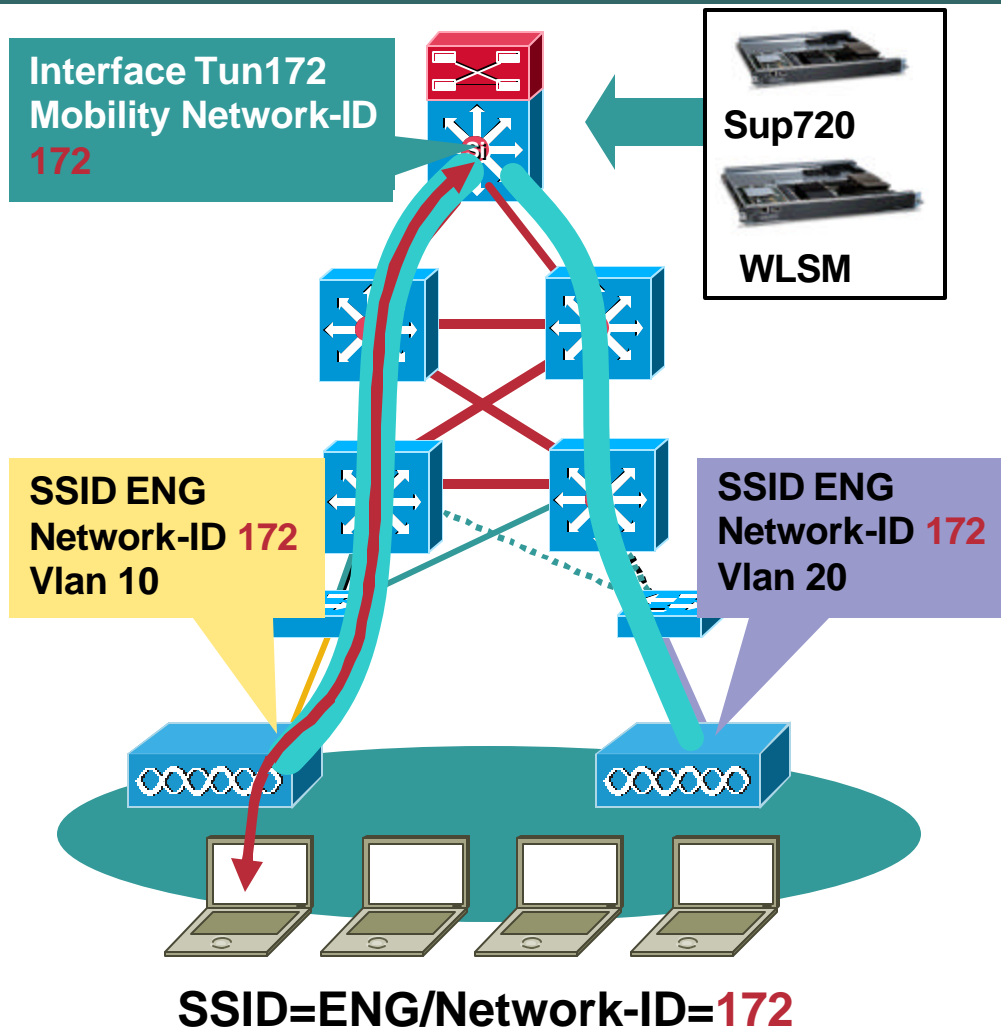

- A Mobility Group is identified by mapping a SSID to a network-ID
- It replaces the mapping of SSID to a wired VLAN
- Define the same SSID Network-ID pair on all APs where mobility is required
- One mGRE tunnel interface is created for each Mobility Group on Sup720
- One SSID/Network-ID = one subnet

The Architectural Shift: Controller Controllers Virtualize the “VLAN”

Mobility/RF Group = **Engineering**

SSID ↔ “WLAN”

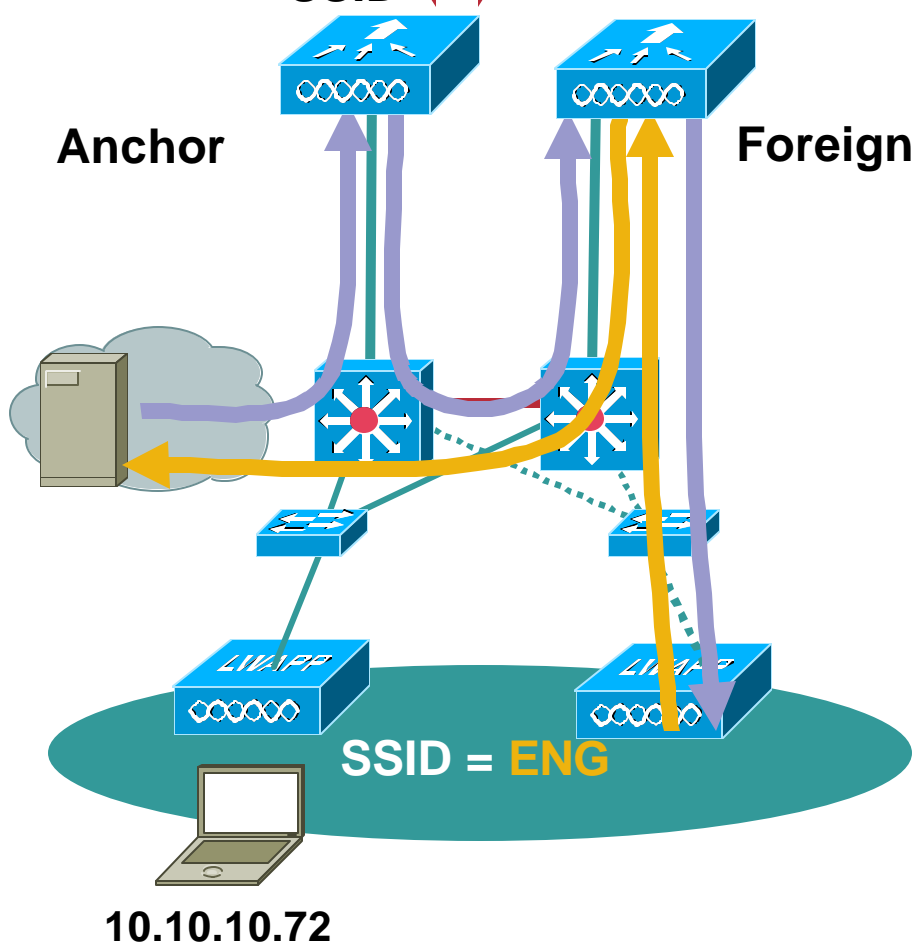

- An SSID is configured with a “WLAN” identifier
- The “WLAN” is configured in all Controllers that define the “Mobility Group” or roaming region
- When a client performs an L3 roam, traffic from the client is bridged directly to the network from the foreign controller
- Return path traffic is forwarded to the anchor controller
- Anchor forwards traffic to the foreign controller

Design Considerations

LWAPP and GRE Tunnel Traffic

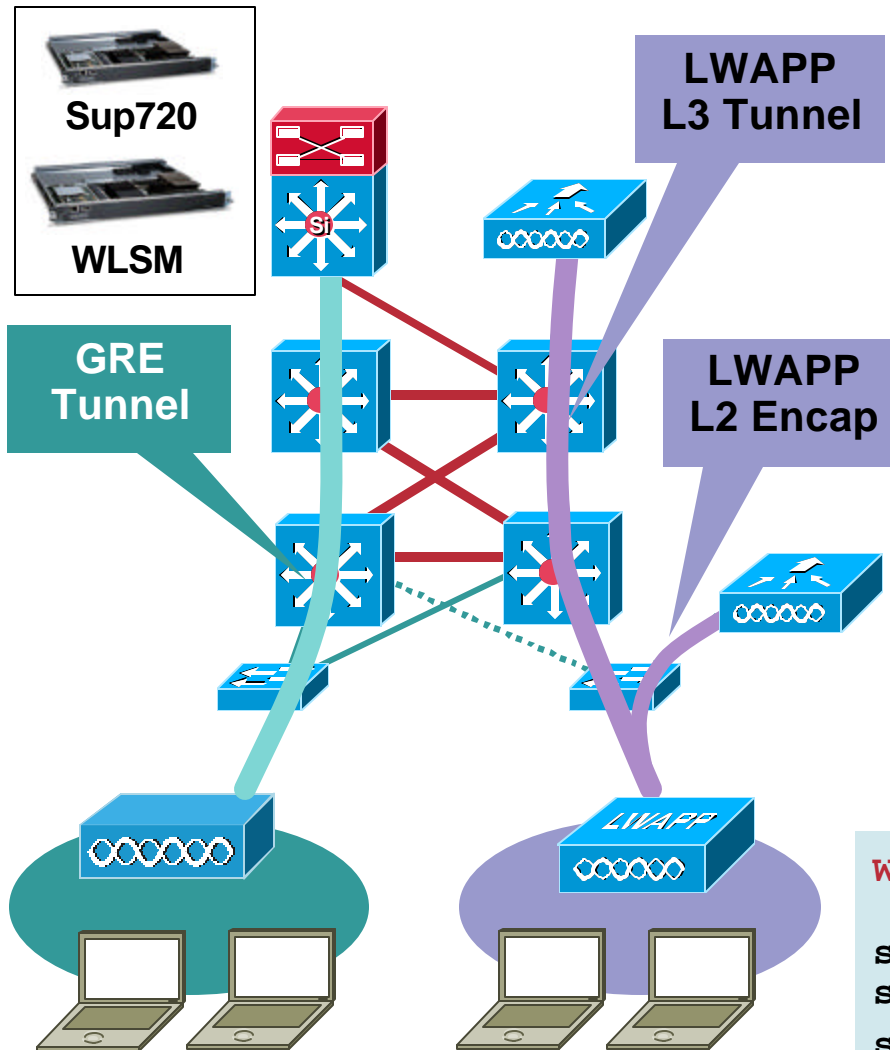

- There must be 'no' NAT between WLSM/WDS and the APs
- If WLSM behind a Firewall open WLCCP (UDP 2887) and GRE (47)
- GRE adds 24 bytes of header therefore need to tune MTU and MSS adjust on the Wireless subnet
- L3 LWAPP adds 94 bytes of headers
- LWAPP AP and Controller will fragment packets if network not configured to support Jumbo frames

WLSM Switch Config (Cat6k Sup720)

```

sup720(config)#int tunnel 172
sup720(config-if)#ip mtu 1476
sup720(config-if)#mobility tcp adjust-mss
    
```

Design Considerations

IP Addressing Considerations

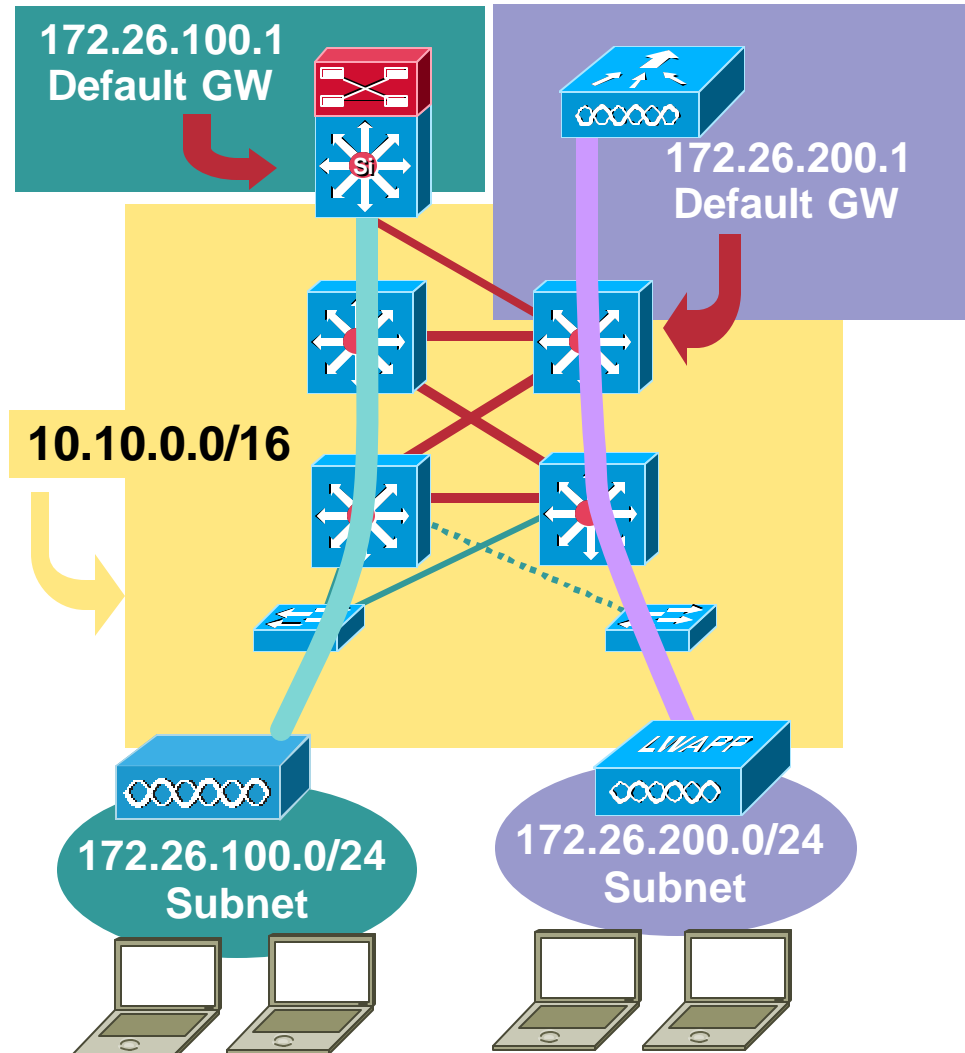

- The default gateway for all wireless endpoints when using a WLSM Controller is the **WLSM Switch**
- The default gateway for all wireless endpoints when using a Cisco Controller is the adjacent Catalyst® switch
- The wireless mobile node endpoints are addressed out of the **summary range** as defined by the location of the controller or the WLSM switch
- Communication between a wired client on an access switch and a wireless client is via the core

Design Considerations

Location of Controllers

- In a small campus with collapsed distribution and core integrate WLSM into core switches
- Large campus integrate WLSM, Controller and radius servers into data center
- Very large campus recommendation is to create a services bldg block
- Controllers logically appear as servers and should be located in server layer

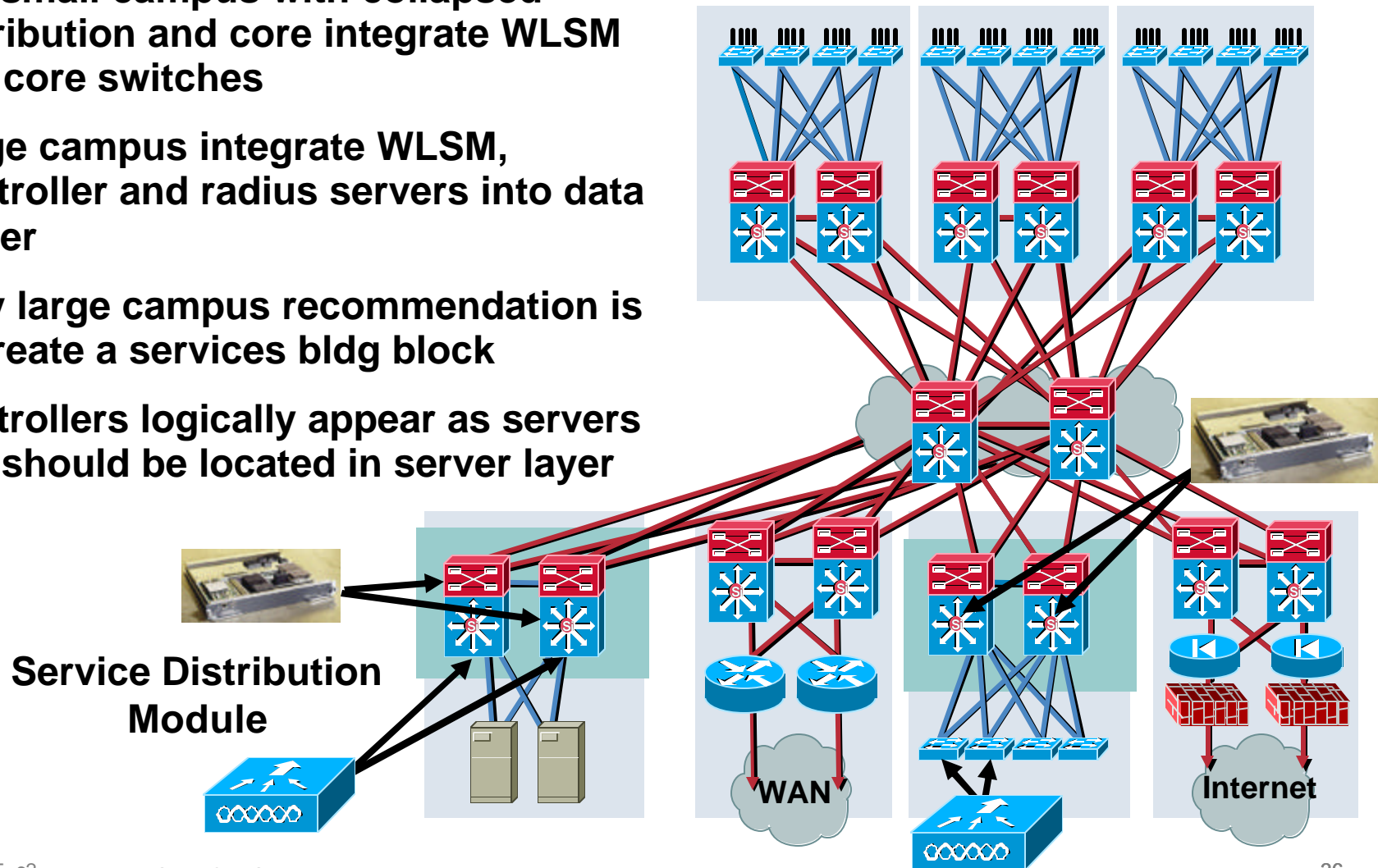

Agenda

- Foundational Design Review
- Convergence—IP Communications
- Wireless LAN and Wireless Mobility
- **High Availability**
 - Alternatives to STP
 - Device HA (NSF/SSO and Stackwise)
 - Resilient Network Design
- Segmentation and Virtualization
 - Access Control (IBNS and NAC)
 - Segmentation
- Questions and Answers

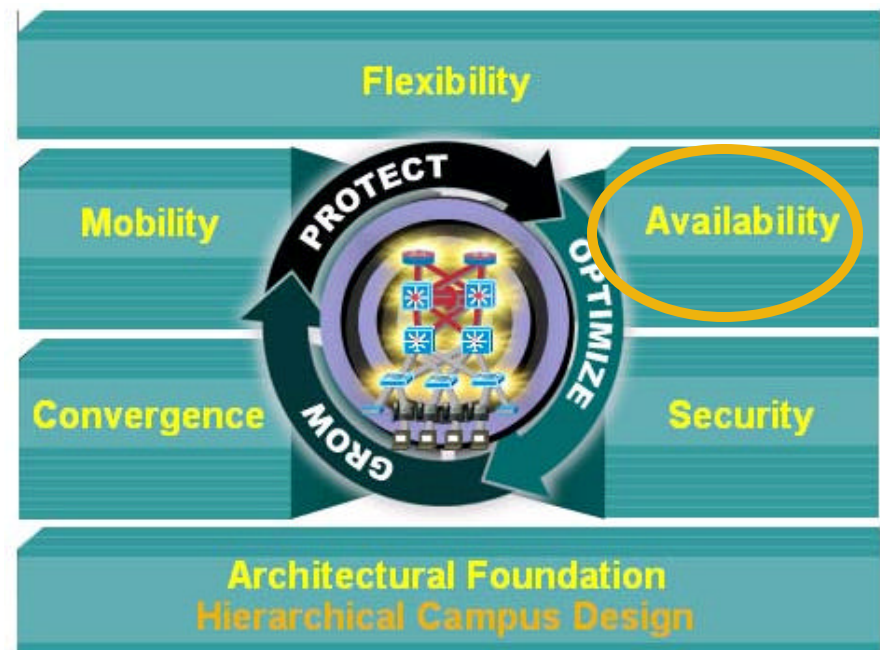

Flex-Link

Link Redundancy

- Flex-link provides a box local link redundancy mechanism
- On failure of the prime link the backup link will start forwarding
- Spanning tree is not involved in link recovery however the network is **'not'** L2 loop free
- Spanning Tree should still be configured on access and distribution switches
- Flex-link reduces size of the spanning tree topology but does **not** make the network loop free
- Supported on 2970, 3550, 3560, 3750 & 6500

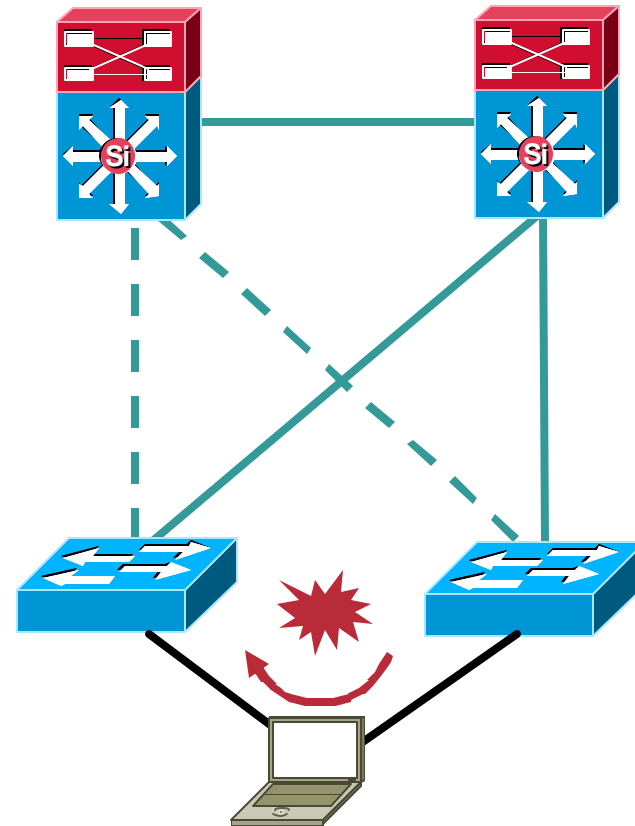

```
interface GigabitEthernet0/1
switchport backup interface GigabitEthernet0/2
```

Routing to the Edge

Layer 3 Distribution with Layer 3 Access

Cisco.com

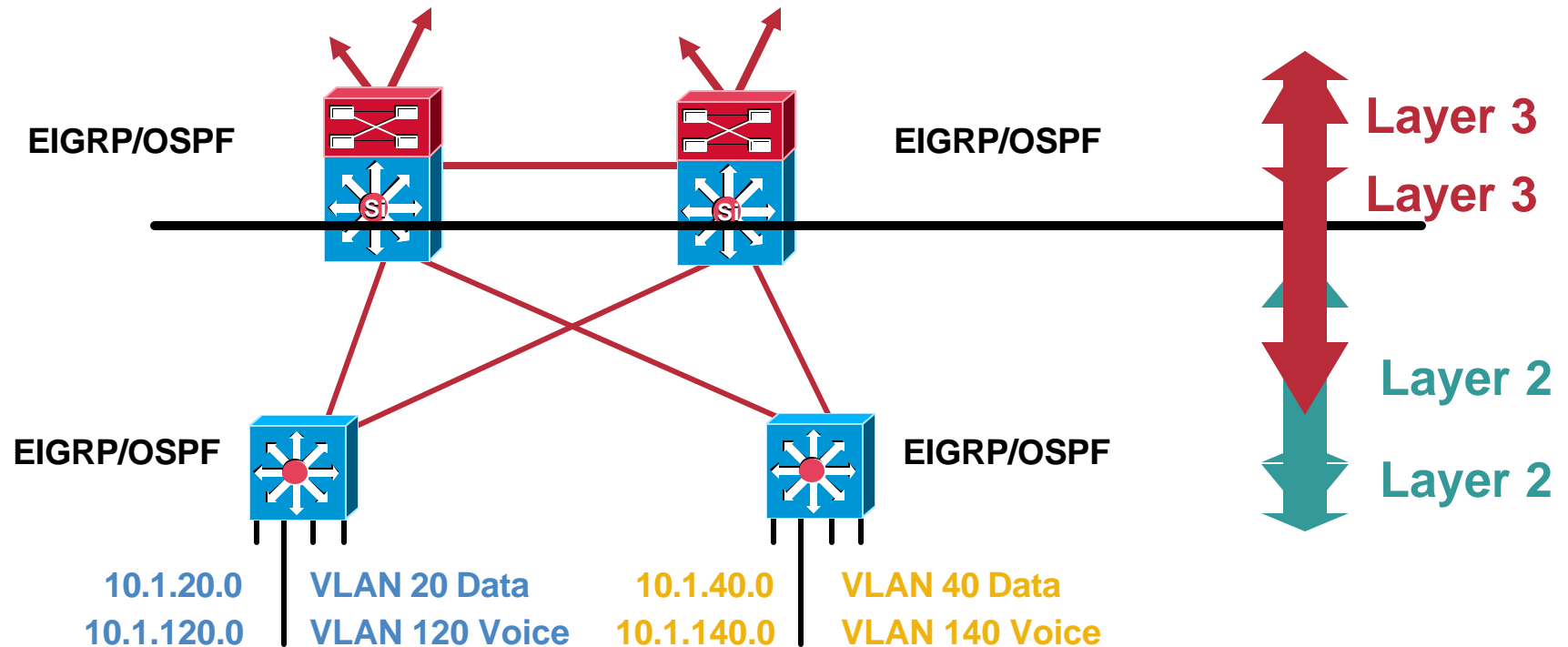

- Move the Layer 2/3 demarcation to the network edge
- Upstream convergence times triggered by hardware detection of light lost from upstream neighbor
- Beneficial for the right environment

Routing to the Edge

Advantages, Yes in the Right Environment

- **Ease of implementation, less to get right**
 - No matching of STP/HSRP/GLBP priority
 - No L2/L3 Multicast topology inconsistencies
- **Single Control Plane and well known tool set**
 - traceroute, show ip route, show ip eigrp neighbor, etc....
- **Most Catalysts support L3 Switching today**
- **EIGRP converges in <200 msec**
- **OPSF with sub-second tuning converges in <200 msec**
- **RPVST+ convergence times dependent on GLBP/HSRP tuning**

Both L2 and L3 Can Provide Sub-Second Convergence

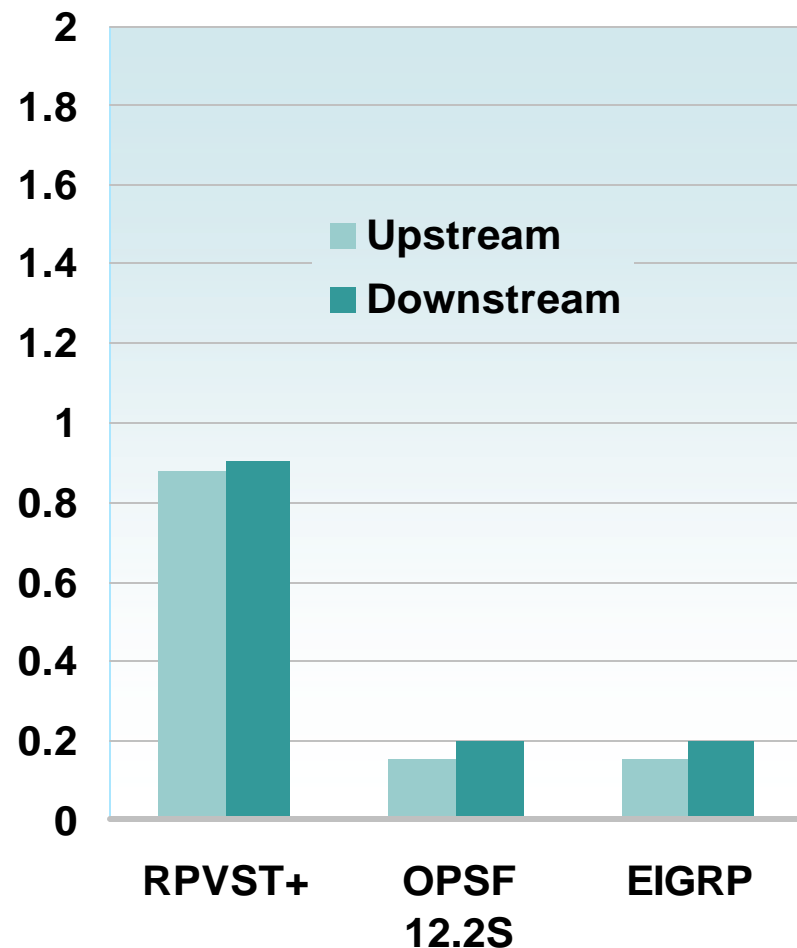

EIGRP Design Rules for HA Campus

High-Speed Campus Convergence

- EIGRP convergence is largely dependent on query response times
- Minimize the number and time for query response to speed up convergence
- Summarize distribution block routes upstream to the core
- Configure all access switches as **EIGRP stub routers**
- Filter routes sent down to access switches

```
interface TenGigabitEthernet 4/1
  ip summary-address eigrp 100 10.120.0.0 255.255.0.0 5

router eigrp 100
  network 10.0.0.0
  distribute-list Default out <mod/port>

ip access-list standard Default
  permit 0.0.0.0

router eigrp 100
  network 10.0.0.0
  eigrp stub connected
```

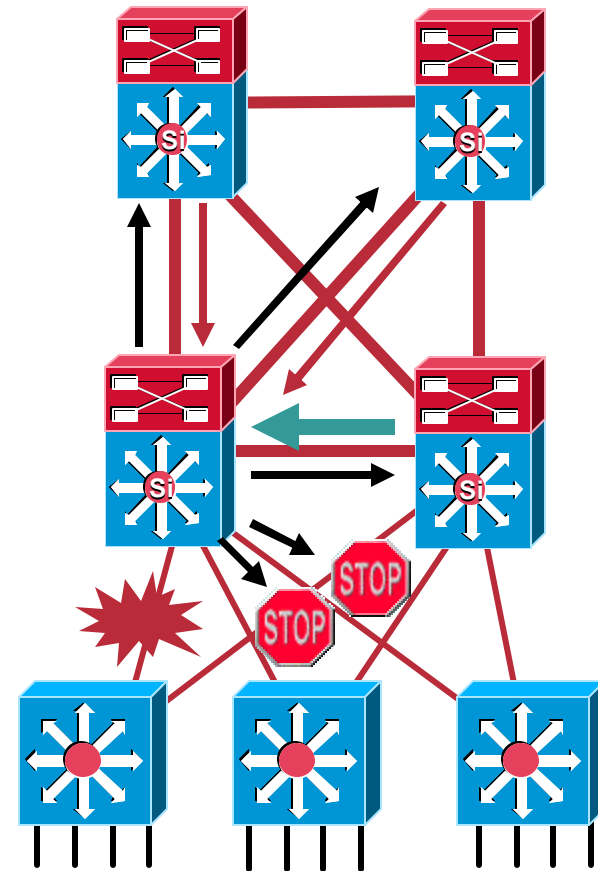

OSPF Design Rules for HA Campus

High-Speed Campus Convergence

Cisco.com

- OSPF convergence is largely dependent on time to compute Dijkstra response times
- In a full meshed design key tuning parameters are **spf throttle** and **lsa throttle**
- Utilize Totally Stubby area design to control number of routes in access switches
- Hello and Dead are secondary failure detection mechanism

```
router ospf 100
router-id 10.122.102.2
log-adjacency-changes
area 120 stub no-summary
area 120 range 10.120.0.0 255.255.0.0
timers throttle spf 10 100 5000
timers throttle lsa all 10 100 5000
timers lsa arrival 80
network 10.120.0.0 0.0.255.255 area 120
network 10.122.0.0 0.0.255.255 area 0
```

```
interface GigabitEthernet5/2
ip address 10.120.100.1 255.255.255.254
ip ospf dead-interval minimal hello-multiplier 4
```

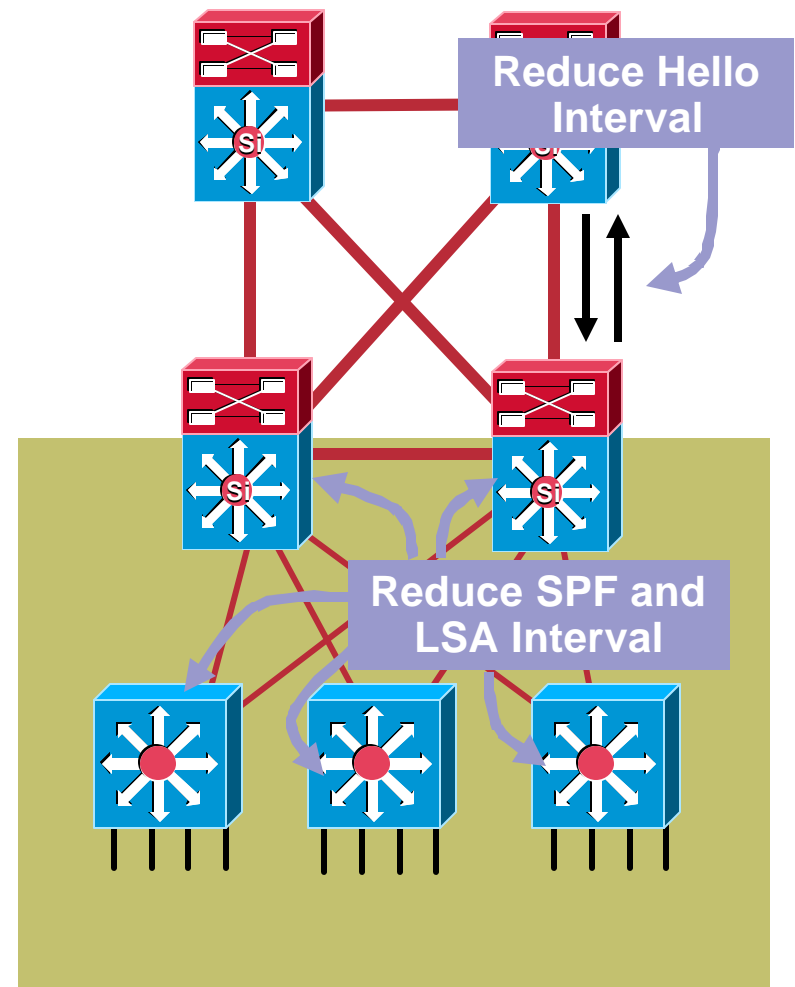

EIGRP vs. OSPF as Your Campus IGP

DUAL vs. Dijkstra

Both Can Provide Subsecond Convergence

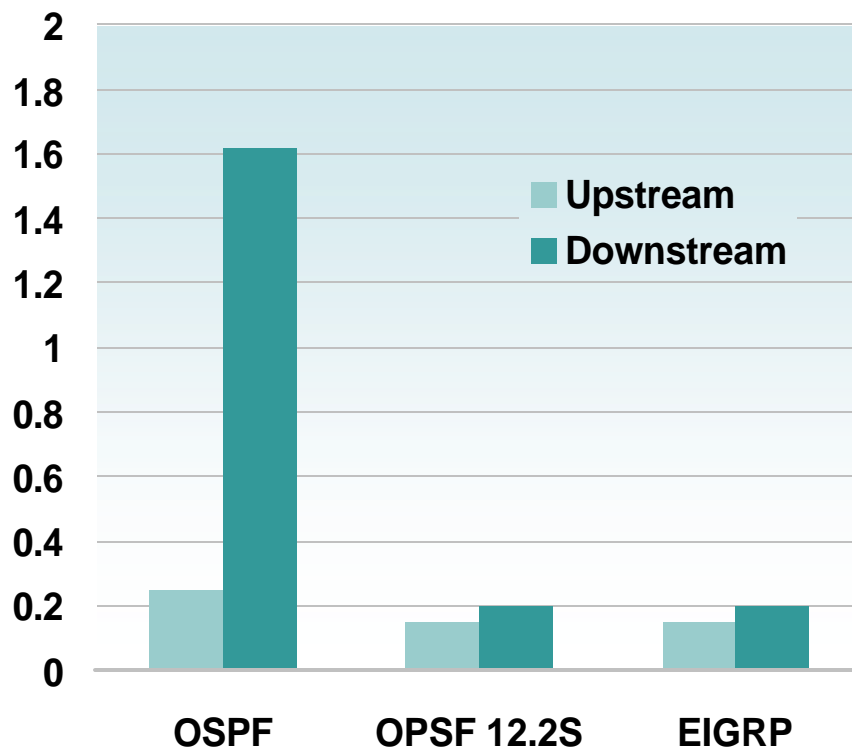

- **Convergence:**
 - Within the campus environment, both EIGRP and OSPF provide extremely fast convergence
 - EIGRP requires summarization and, OSPF requires LSA and SPF timer tuning for fast convergence
- **Flexibility:**
 - EIGRP supports multiple levels of route summarization and route filtering which simplifies migration from the traditional Multilayer L2/L3 Campus design
 - OSPF Area design restrictions need to be considered
- **Scalability:**
 - Both protocols can scale to support very large Enterprise Network topologies

For More Discussion on Routed Access Design Best Practices—RST-2031

Agenda

- Foundational Design Review
- Convergence—IP Communications
- Wireless LAN and Wireless Mobility
- **High Availability**
 - Alternatives to STP
 - Device HA (NSF/SSO and Stackwise)**
 - Resilient Network Design
- **Segmentation and Virtualization**
 - Access Control (IBNS and NAC)
 - Segmentation
- Questions and Answers

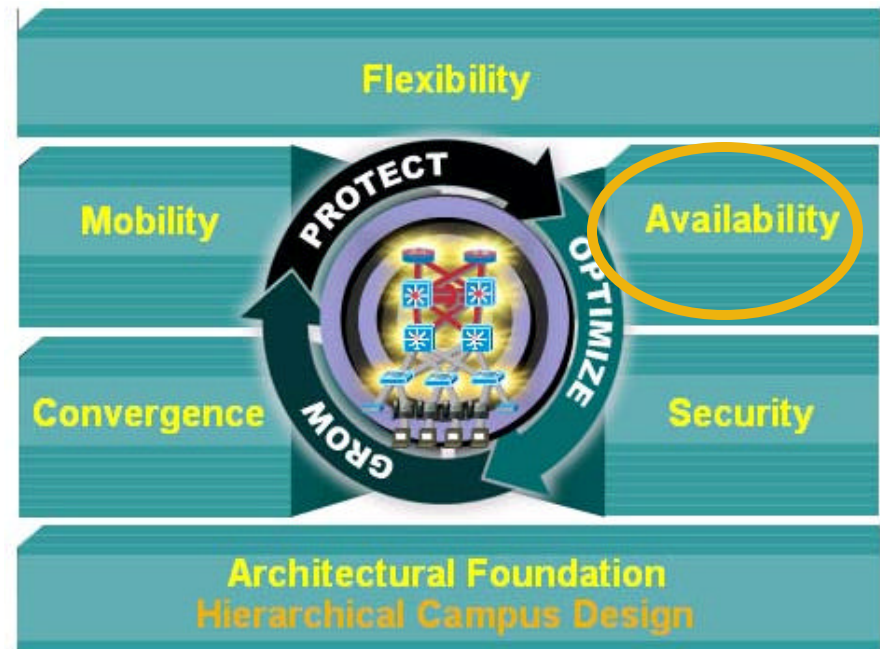

Device High Availability

NSF/SSO and 3750 Stackwise

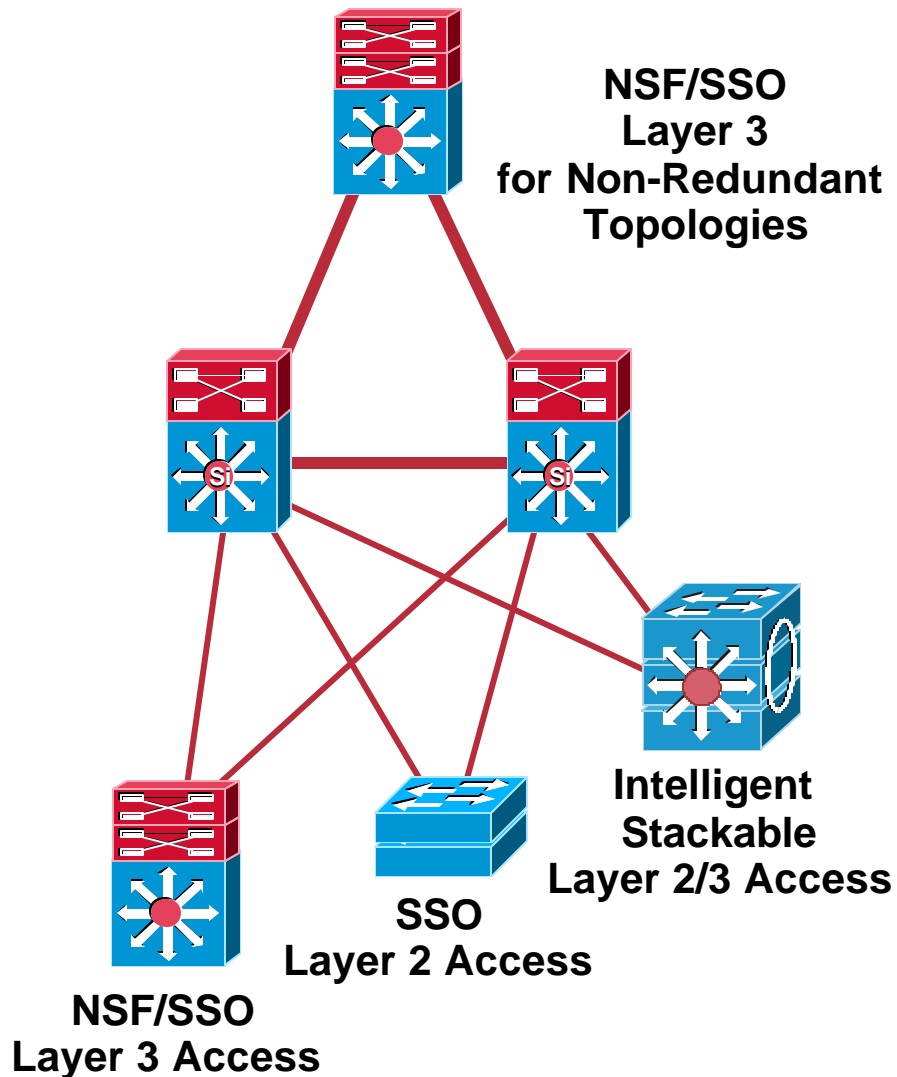

- Overall availability of the infrastructure is dependent on the weakest link
- NSF/SSO provides improved availability for single points of failure
- SSO provides enhanced redundancy for traditional Layer 2 edge designs
- NSF/SSO provides enhanced L2/L3 redundancy for routed to the edge designs
- 3750 Stackable provides improved redundancy for L2 and L3 edge designs

Supervisor Processor Redundancy

Stateful Switch Over (SSO)

Cisco.com

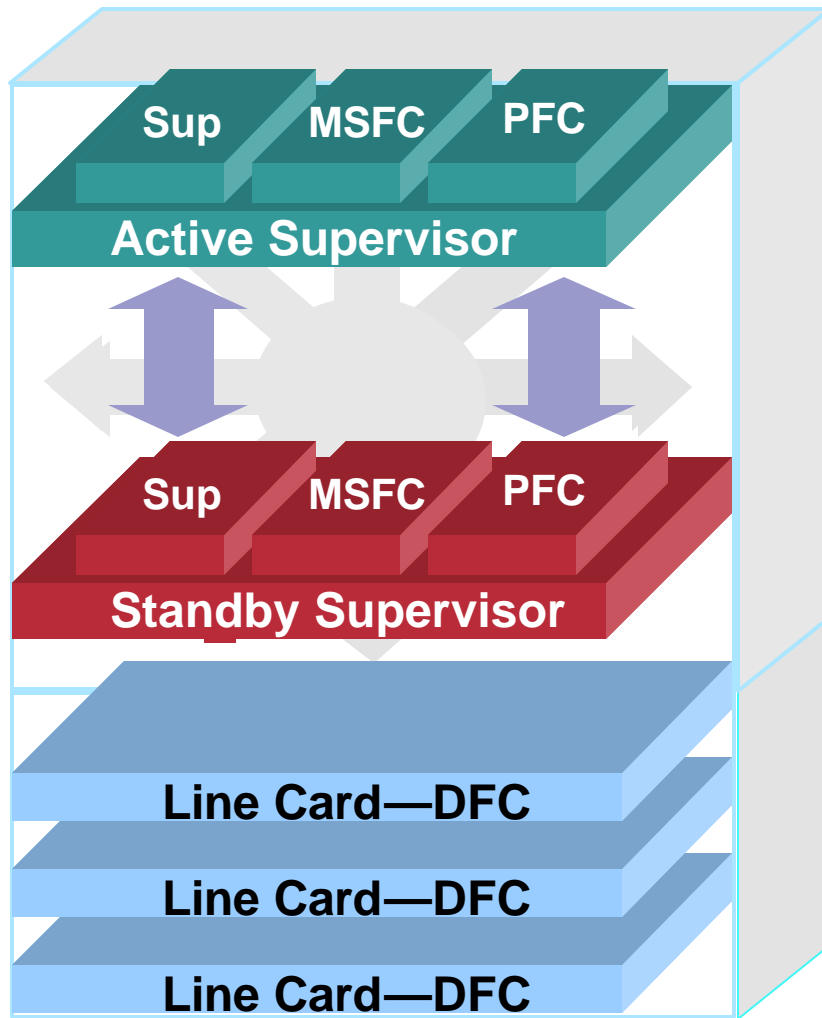

- Active/standby supervisors run in synchronized mode
- Redundant MSFC is in 'hot-standby' mode
- Switch processors synchronize L2 port state information, (e.g. STP, 802.1x, 802.1q,...)
- PFCs synchronize L2/L3 FIB, Netflow and ACL tables
- DFCs are populated with L2/L3 FIB, Netflow and ACL tables

Non-Stop Forwarding (NSF)

NSF Recovery

1. DFC enabled line cards continue to forward based on existing FIB entries
2. Following SSO recovery and activation of standby Sup synchronized PFC continues to forward traffic based on existing FIB entries
3. “Hot-Standby” MSFC RIB is detached from the FIB isolating FIB from RP changes
4. “Hot-Standby” MSFC activates routing processes in NSF recovery mode
5. MSFC re-establishes adjacency indicating this is an NSF restart
6. Peer updates restarting MSFC with it’s routing information
7. Restarting MSFC sends routing updates to the peer
8. RIB reattaches to FIB and PFC and DFCs updated with new FIB entries

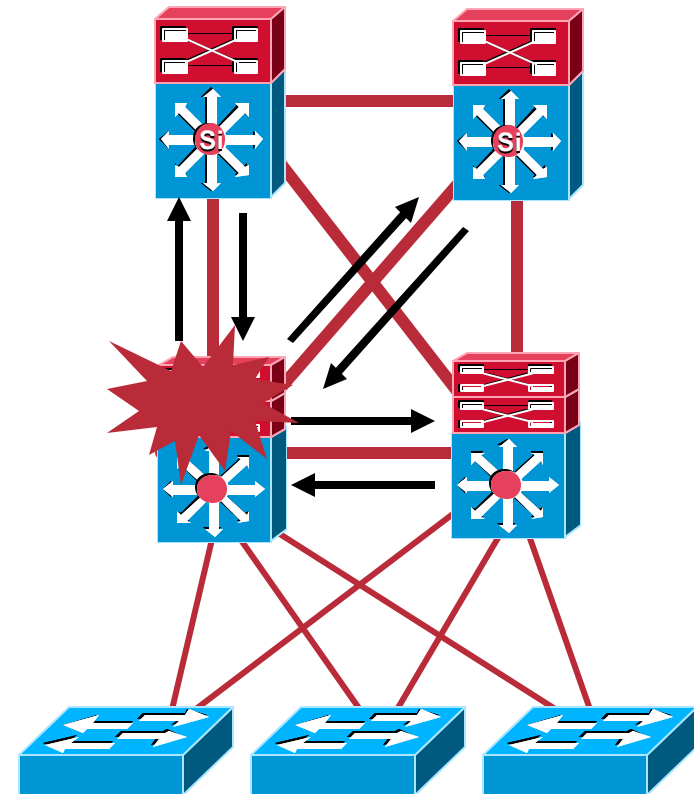

No Route Flaps During Recovery

Non-Stop Forwarding (NSF)

NSF Capable vs. NSF Awareness

- Two roles in NSF neighbor graceful restart
 - NSF Capable
 - NSF Aware
- An NSF-Capable router is 'capable' of continuous forwarding while undergoing a switchover
- An NSF-Aware router is able to assist NSF-Capable routers by:
 - Not resetting adjacency
 - Supplying routing information for verification after switchover
- NSF capable and NSF aware peers cooperate using Graceful Restart extensions to BGP, OSPF, ISIS and EIGRP protocols

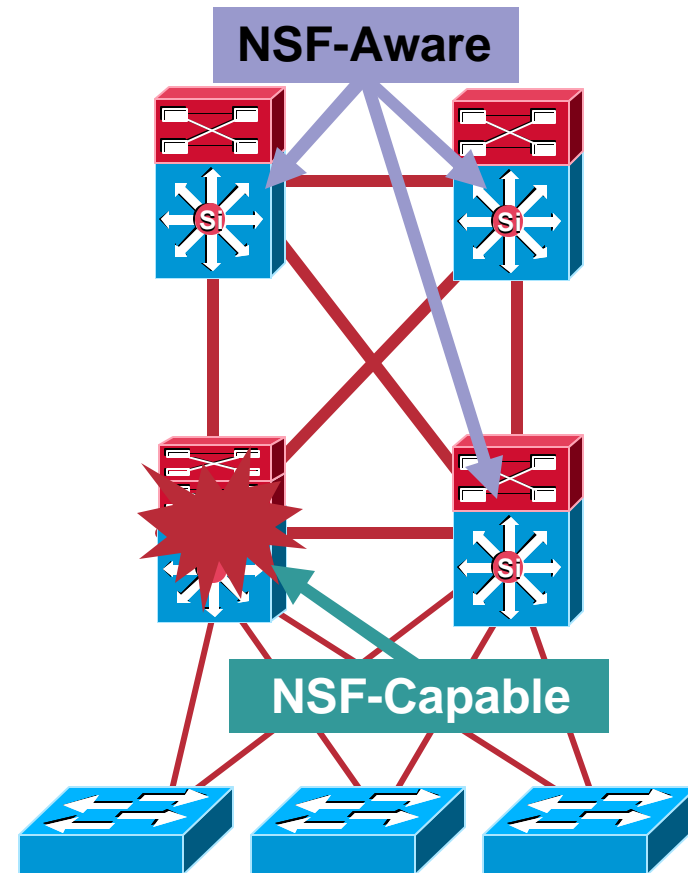

Design Considerations for NSF/SSO

NSF and Hello Timer Tuning?

- NSF is intended to provide availability through route convergence **avoidance**
- Fast IGP timers are intended to provide availability through fast route **convergence**
- In an NSF environment dead timer must be greater than SSO Recovery + RP restart + time to send first hello
 - OPSF 2/8 seconds for hello/dead
 - EIGRP 1/4 seconds for hello/hold
- In a Campus environment composed of pt-pt fiber links neighbor loss is detected via loss of light
- RP timers providing a backup recovery role only

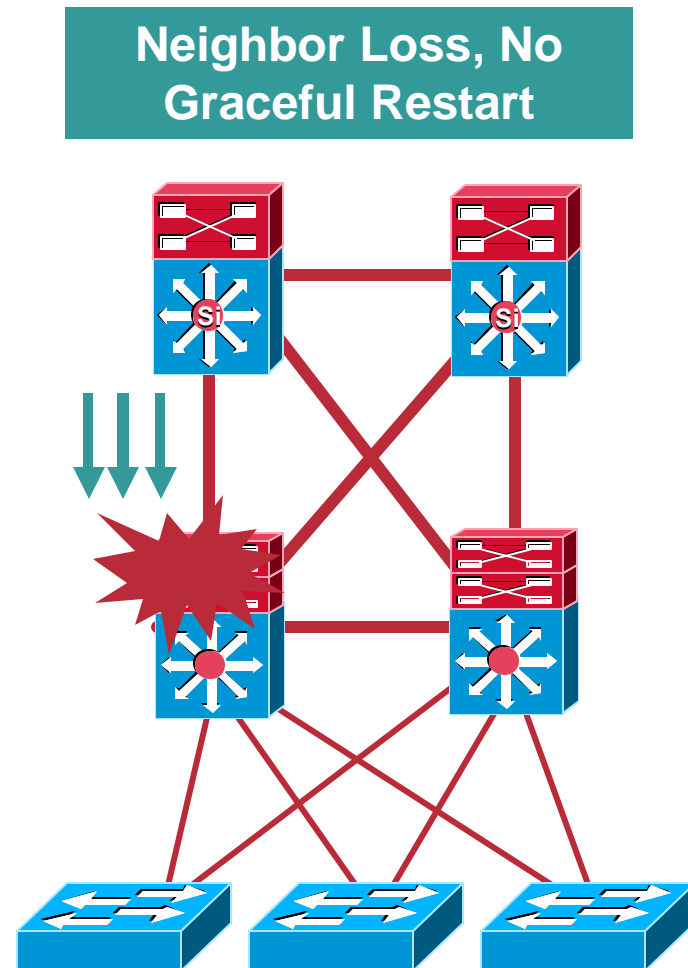

Design Considerations for NSF/SSO

Supervisor Uplinks

- The use of Supervisor uplinks with NSF/SSO results in a more complex network recovery scenario
- Dual failure scenario
 - Supervisor Failure
 - Port Failure
- During recovery FIB is frozen but uplink port is gone
- PFC tries to forward out a non-existent link
- Bundling Supervisor uplinks into Etherchannel links improves convergence
- Optimal NSF/SSO convergence requires the use of DFC enabled line cards

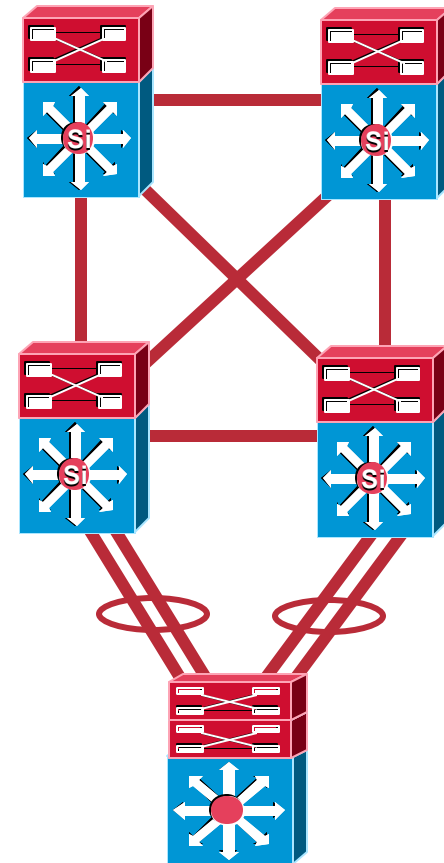

Uplinks on Line Card (msec)	SVI (Etherchannel)	Routed interfaces
920 msec	3100 msec	24 sec

Design Considerations for NSF/SSO

Where Does It Make Sense?

- Redundant topologies with equal cost paths provide sub-second convergence
- NSF/SSO provides superior availability in environments with non-redundant paths

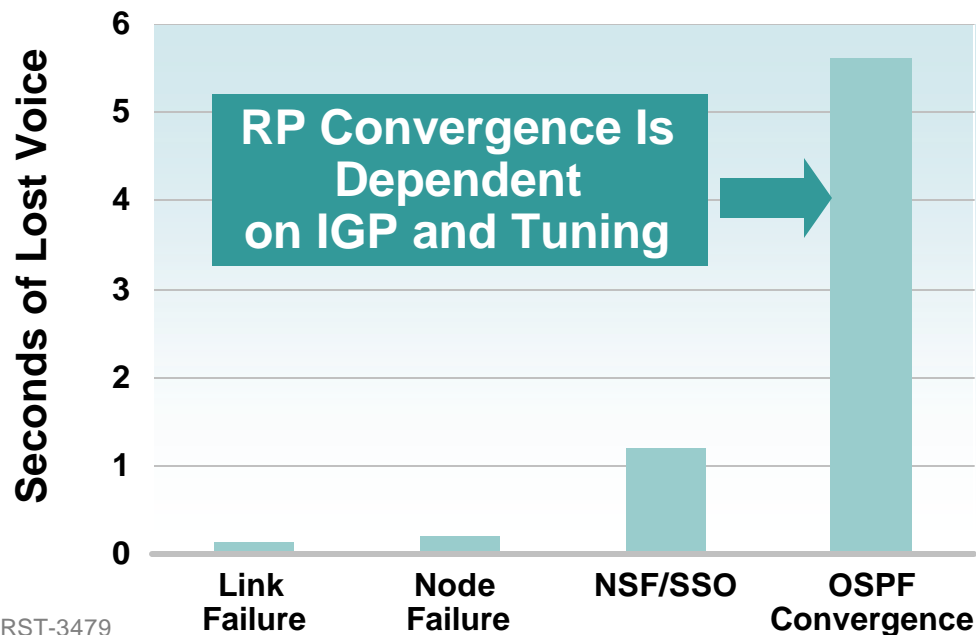
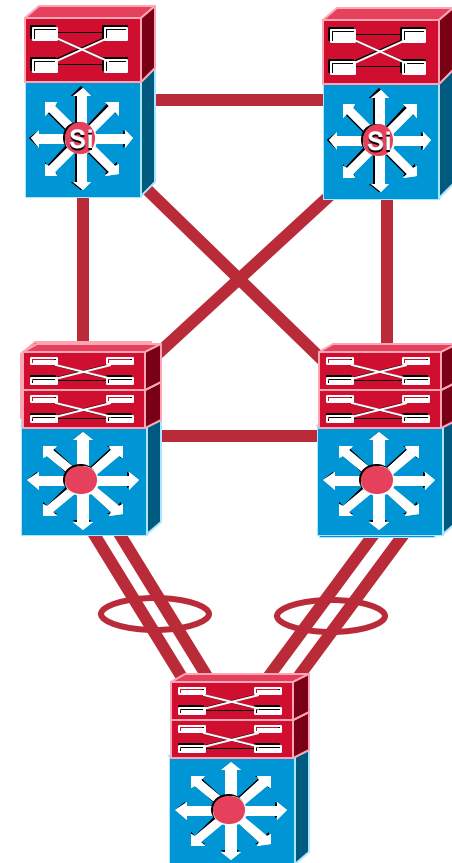

Design Considerations for NSF/SSO

Where Does It Make Sense?

- Access switch is the **single point of failure** in best practices HA campus design
- Supervisor failure is most common cause of access switch service outages
- SSO provides for sub-second recovery of voice and data traffic
- NSF/SSO provides for sub 1200 msec recovery of voice and data traffic

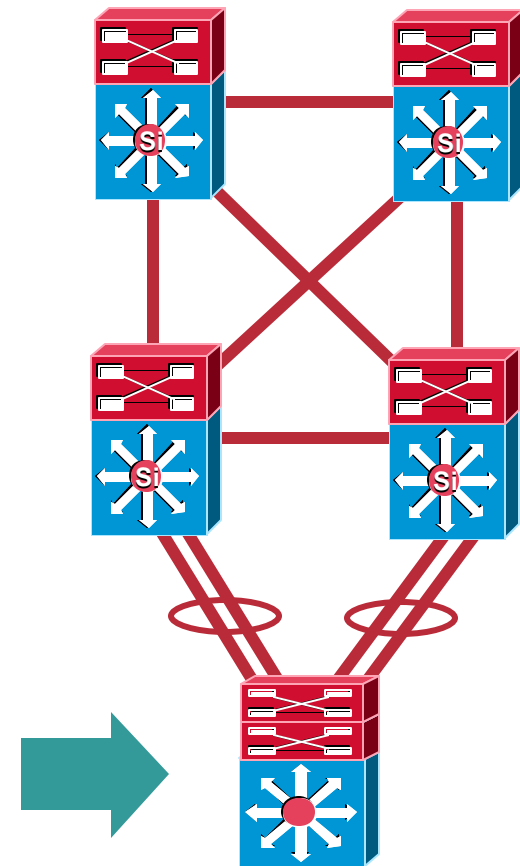
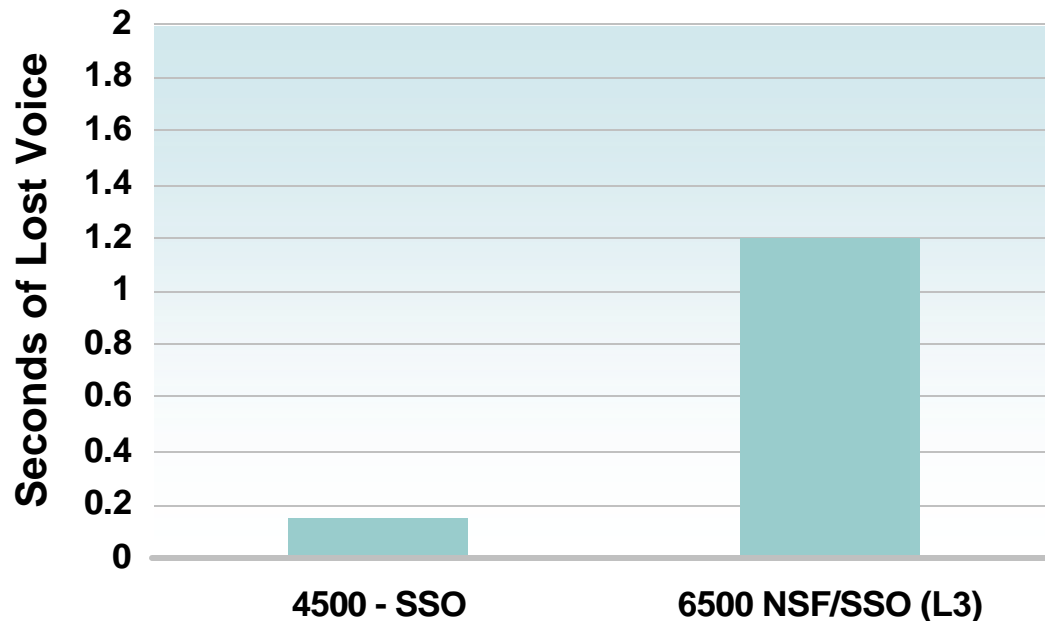

Device High Availability

3750 Stackwise

- Centralized Configuration and Management
- Switching fabric extended via bidirectional self healing ring
- Each TCAM contains full FIB, ACL and QoS information
- Certain functions are replicated on all switches (e.g. VLAN database, Spanning Tree,...)
- Other functions are managed centrally on the stack master node (e.g. L3 is centrally managed)
- Redundancy is provided via a combination of distributed feature replication and RPR+ like master/slave failover

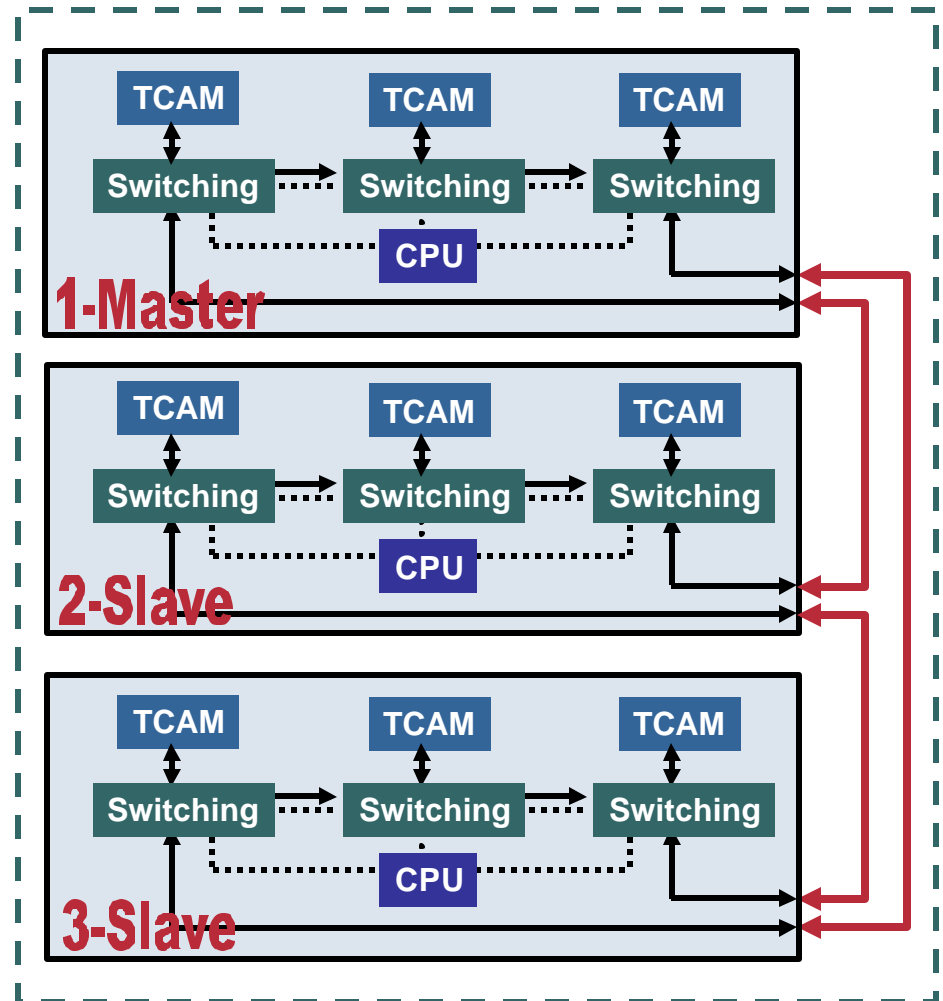

Design Considerations

Chassis vs. Stackable?

- Chassis-based systems provide full 1:1 component redundancy
 - No loss in system switching capacity
 - All edge ports protected
- NSF/SSO enabled chassis systems provide for both device and network level redundancy
- Both provide sub-second L2 convergence
- Both support five 9s Campus HA design

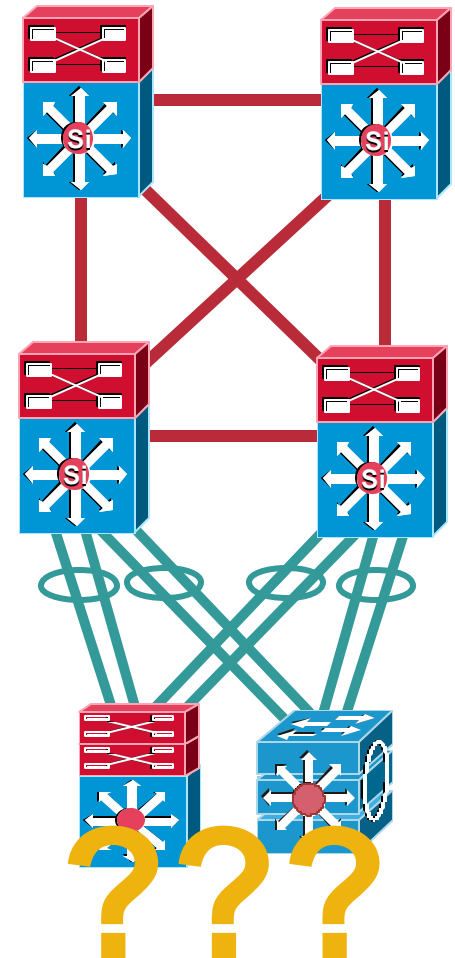
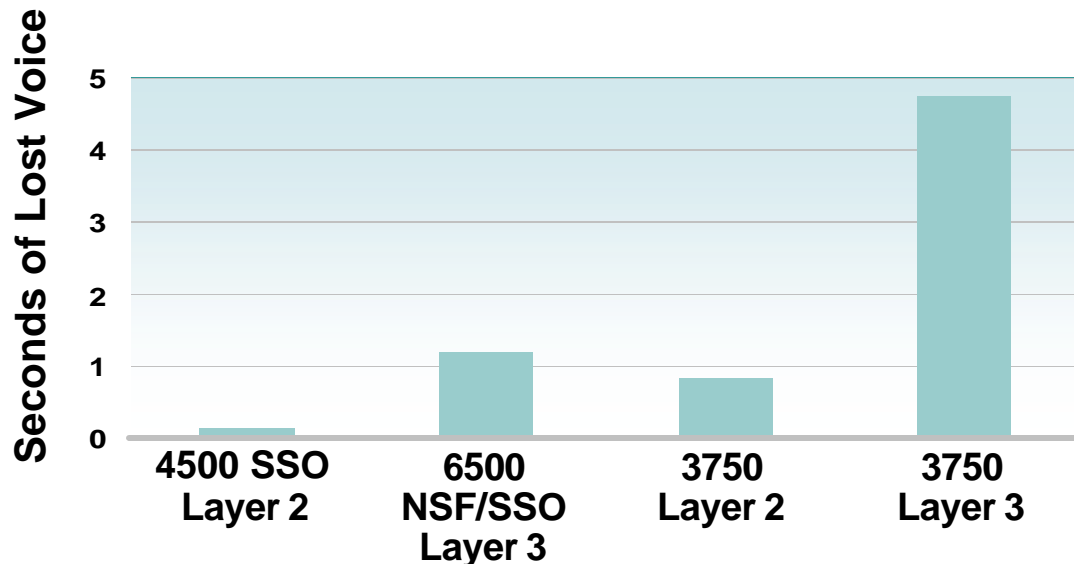

Agenda

- Foundational Design Review
- Convergence—IP Communications
- Wireless LAN and Wireless Mobility
- **High Availability**
 - Alternatives to STP
 - Device HA (NSF/SSO and Stackwise)
 - Resilient Network Design**
- **Segmentation and Virtualization**
 - Access Control (IBNS and NAC)
 - Segmentation
- Questions and Answers

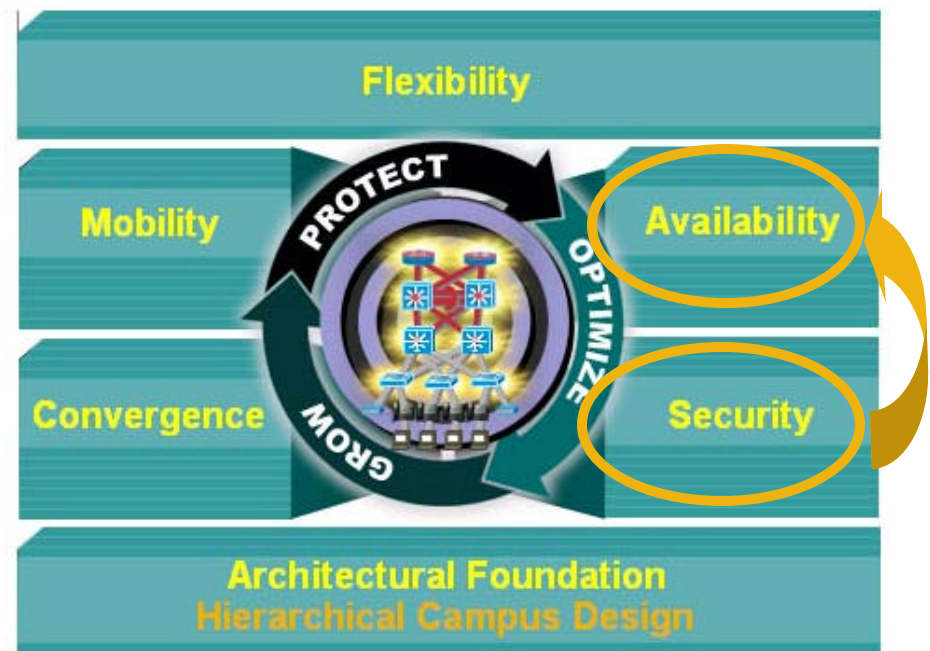

The Resilient Campus Network

Evolution Beyond Structured Design

- We engineer networks for the expected
- We also need to design for the **unexpected**
- Campus design should consider how to prevent or restrict **anomalous** or bad behaviour
- Understand and mitigate the threats at each layer of the network
- Protect network resources

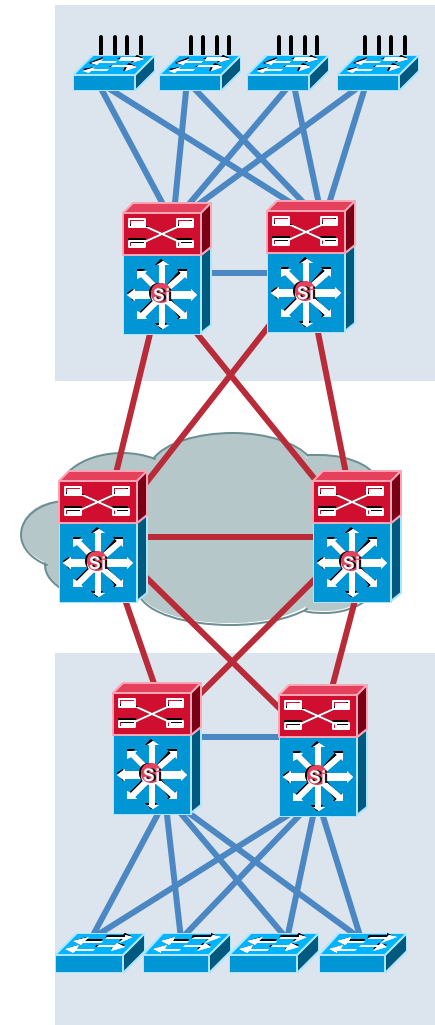
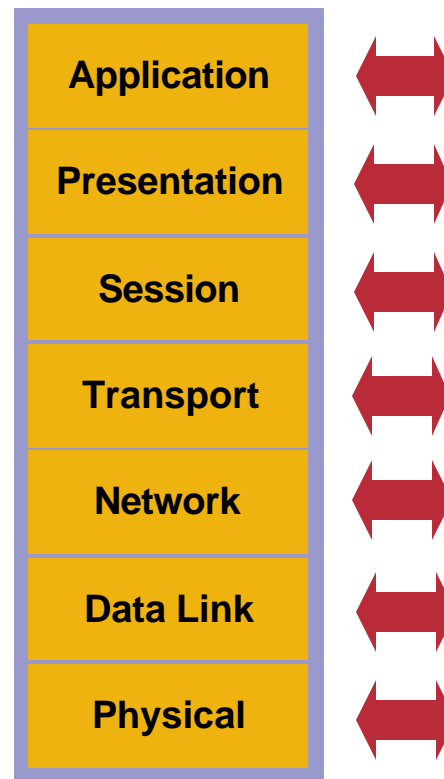

Impact of an Internet Worm

Direct and Collateral Damage

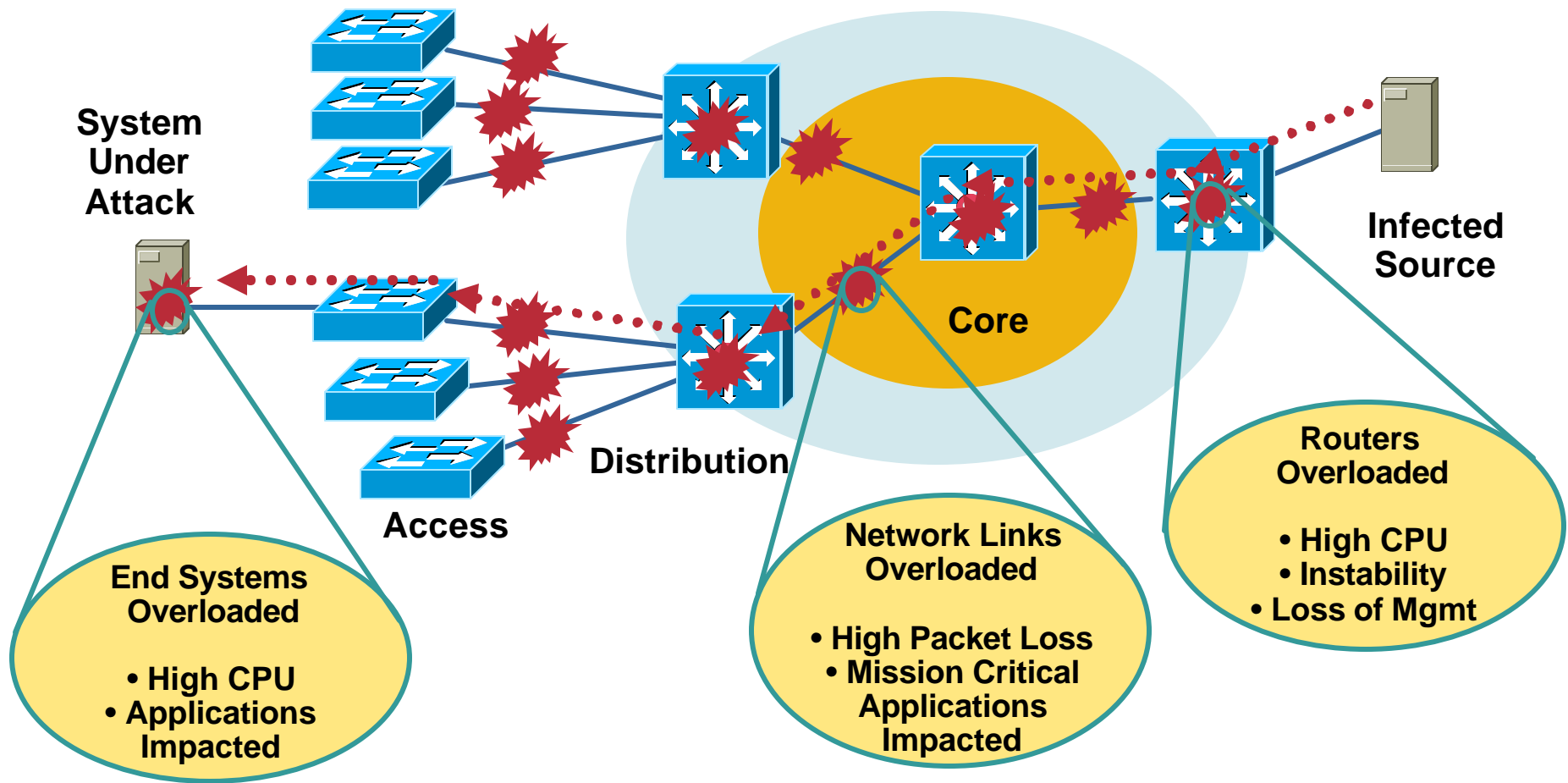

Availability of **Networking Resources** Impacted by the Propagation of the Worm

Mitigating the Impact

Preventing and Limiting the Pain

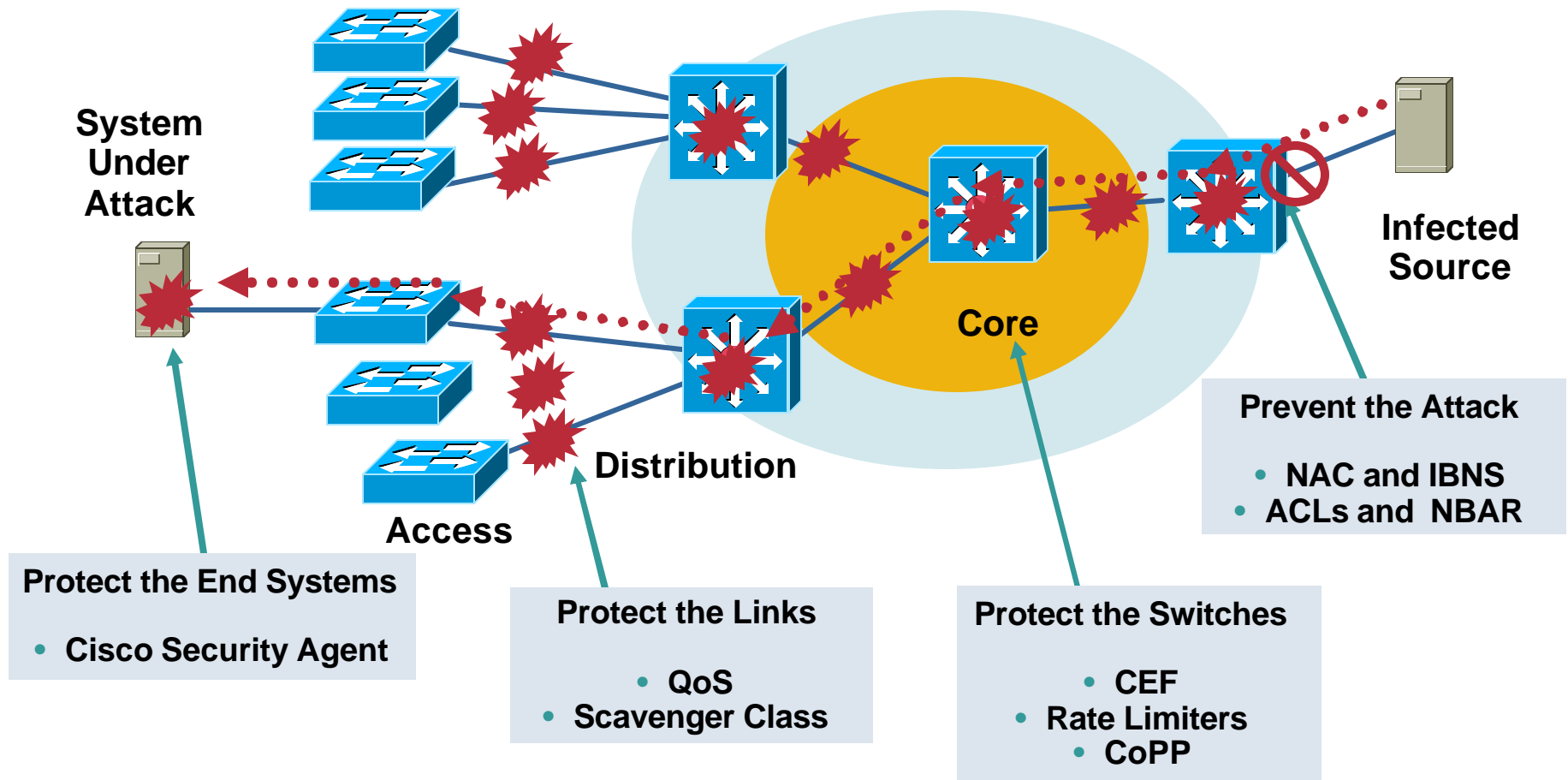

**Allow the Network to Do What You Designed It to Do
but Not What You Didn't**

Worms Are Only One Problem

Other Sources of Pain

- Internet Worms are not the only type of network anomaly
- Multiple things can either go wrong or be happening that you want to prevent and/or mitigate

Spanning Tree Loops

NICs spewing garbage

Distributed Denial of Service (DDoS)

TCP Splicing, ICMP Reset attacks

Man in the Middle (M-in-M) attacks

...

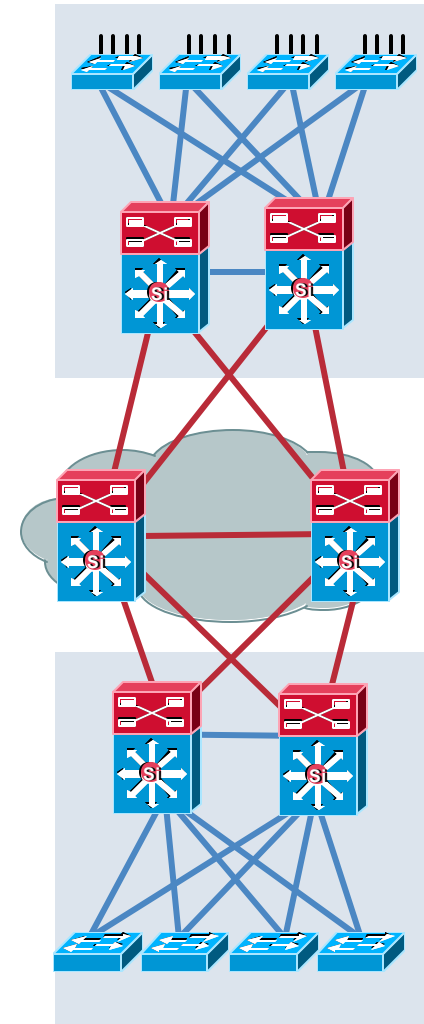

Catalyst Integrated Security Features

Hardening Layer 2/3

Cisco.com

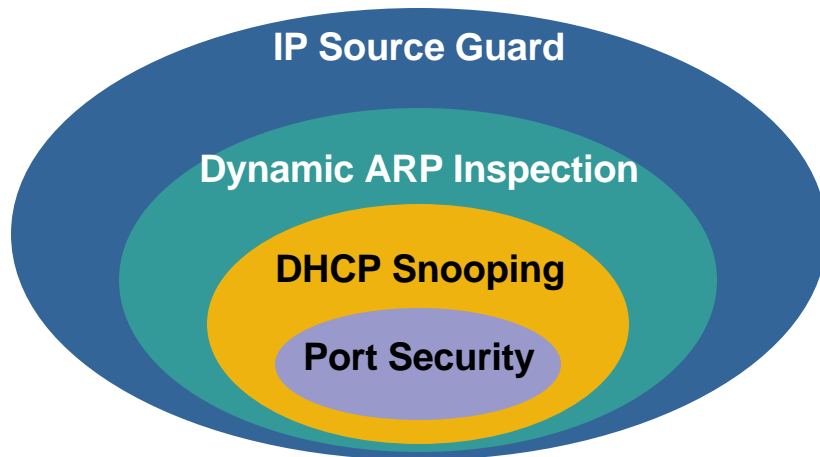

- **Port Security** prevents MAC flooding attacks
- **DHCP Snooping** prevents client attack on the switch and server
- **Dynamic ARP Inspection** adds security to ARP using DHCP snooping table
- **IP Source Guard** adds security to IP source address using DHCP snooping table

```
ip dhcp snooping
ip dhcp snooping vlan 2-10
ip arp inspection vlan 2-10
!
interface fa3/1
switchport port-security
switchport port-security max 3
switchport port-security violation
restrict
switchport port-security aging time 2
switchport port-security aging type
inactivity
ip arp inspection limit rate 100
ip dhcp snooping limit rate 100
!
interface gigabit1/1
ip dhcp snooping trust
ip arp inspection trust
```

Catalyst Integrated Security Features

Hardening Layer 2/3

Port Security

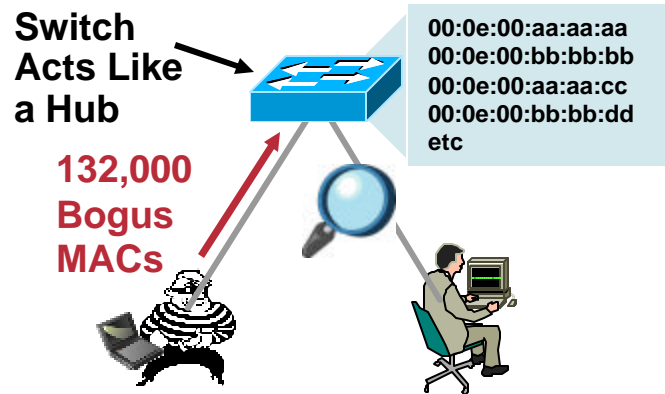

IP Source Guard

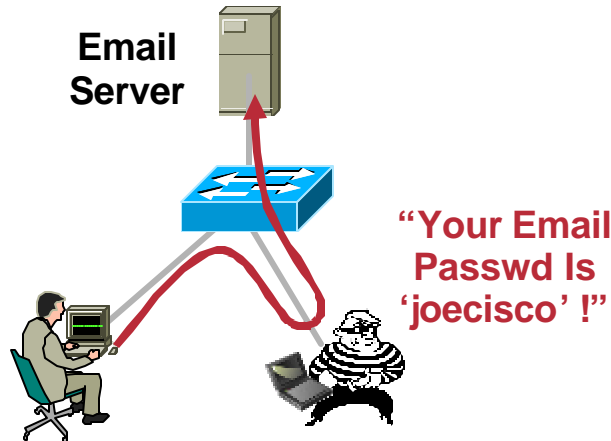

- Plugging all of the Layer 2 security holes also serves to prevent a whole suite of other attack vectors
- Port security mitigates against most Layer 2 based CPU DoS attacks
- In addition to preventing M-i-M attacks IP source guard prevents

DDoS attacks which utilize a spoofed source address, e.g. **TCP SYN Floods, Smurf**

TCP splicing and RST attacks

IP Source Guard vs. uRPF

Preventing Layer 3 Spoofing Attacks

- **Problem:** Infected PC launches a DoS attack using spoofed source address
- Unicast Reverse Path Forwarding (uRPF) checks to see if incoming port is the best route to the source address
- uRPF operates in Strict or Loose mode
- Strict mode complex in a redundant environment
- Loose mode is very valuable for Black Hole Routing
- **IP Source Guard** is the best answer to this problem

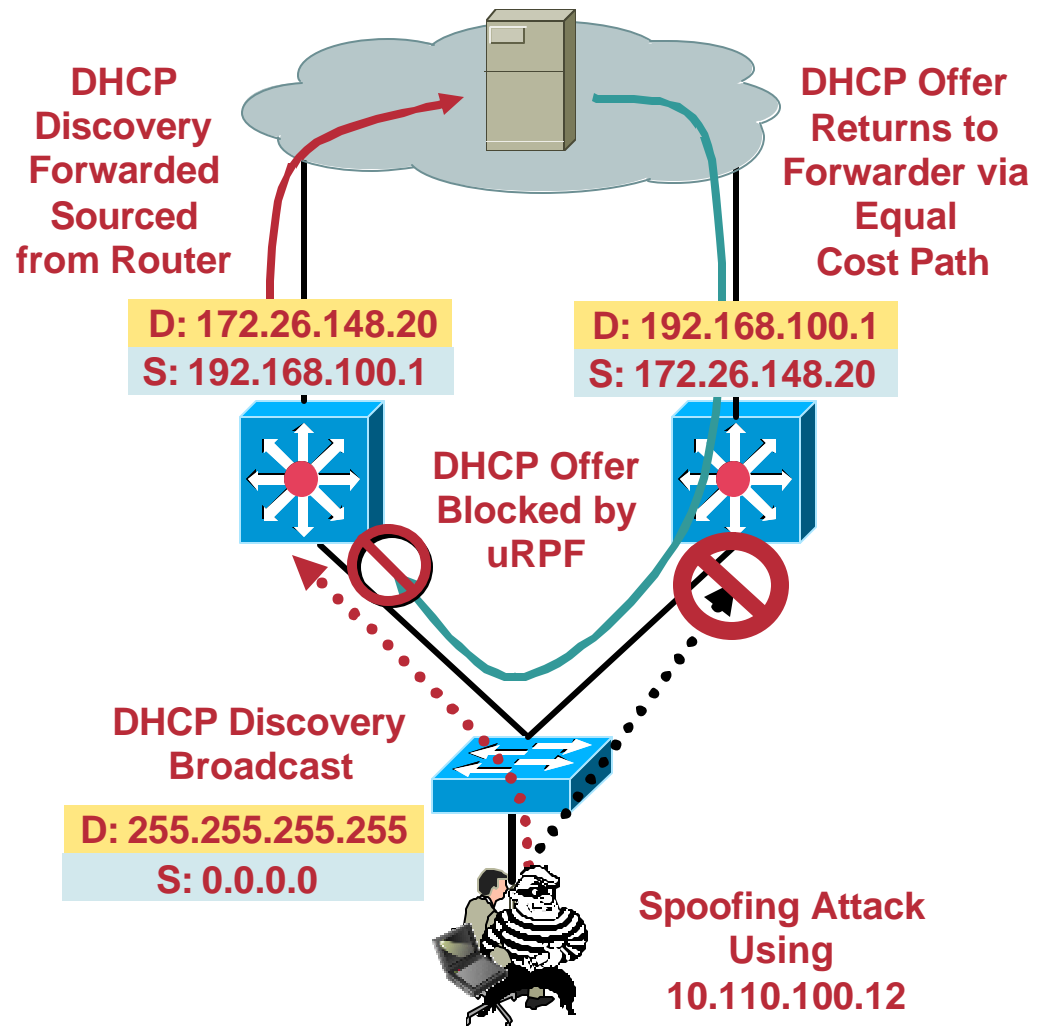

Layer 2 Hardening

Spanning Tree Should Behave the Way You Expect

Cisco.com

- **The root bridge should stay where you put it**

Loopguard and Rootguard
UDLD

- **Only end station traffic should be seen on an edge port**

BPDU Guard
port-security

- **There is a reasonable limit to B-Cast and M-Cast traffic volumes**

Configure Storm control on backup links to aggressively rate limit B-Cast and M-Cast
Utilize Sup720 Rate limiters or SupIV/V with HW queuing structure

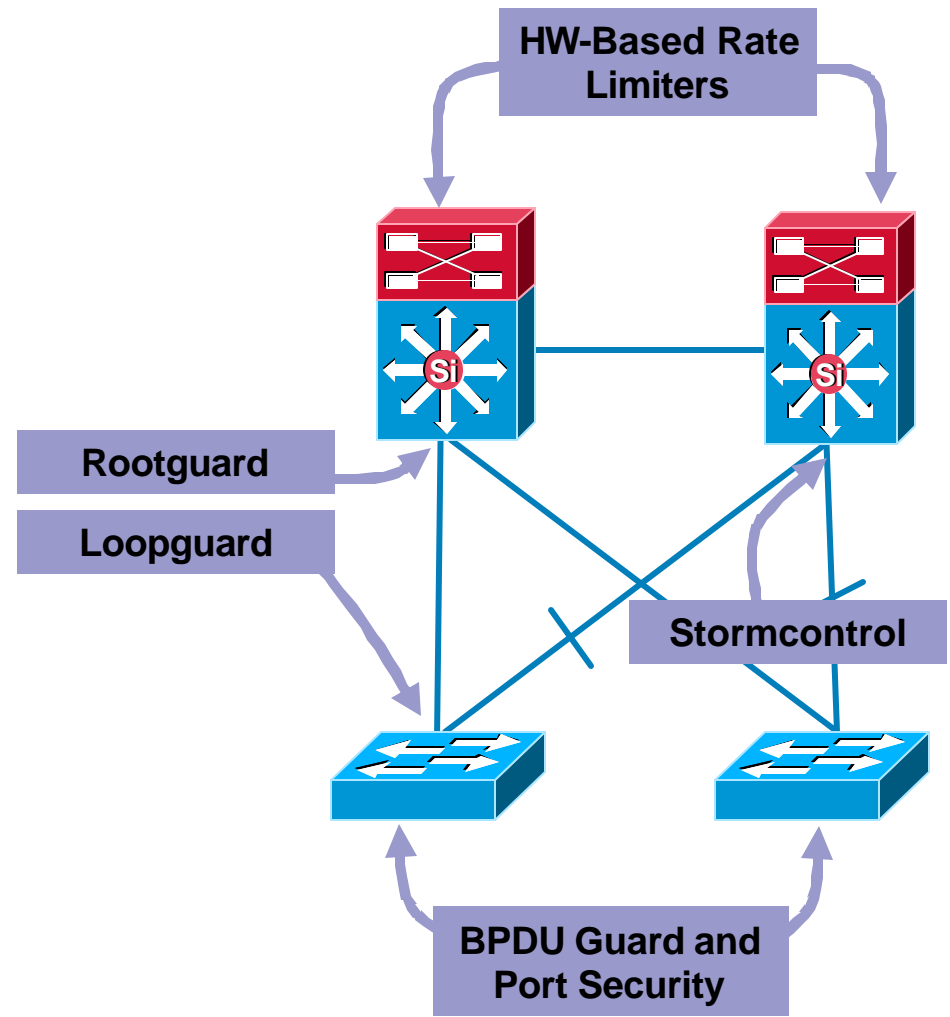

Harden the Network Links

Storm Control

- Protect the network from intentional and unintentional flood attacks
e.g. STP loop
- Limit the combined rate of broadcast and multicast traffic to **normal** peak loads
- Limit broadcast and when possible multicast to 1.0% of a GigE link to ensure distribution CPU stays in safe zone

Broadcast Traffic CPU Impact

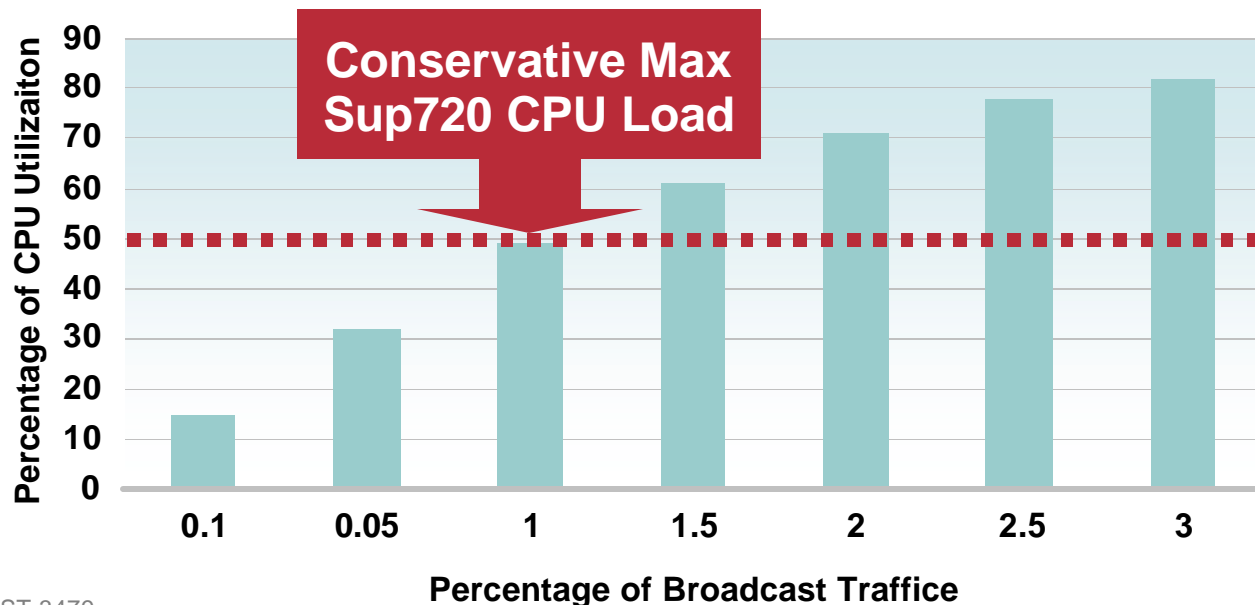

```
! Enable storm control
storm-control broadcast
level 1.0
storm-control multicast
level 1.0
```

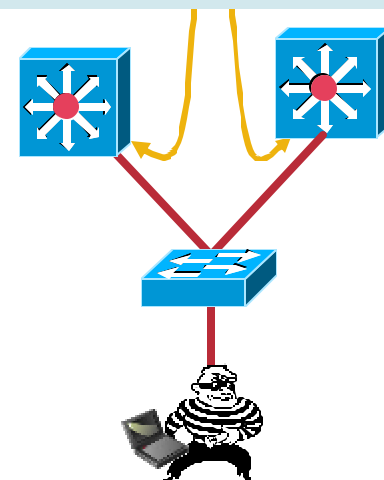

Harden the Network Links—QoS

Scavenger-Class QoS

- All end systems generate traffic spikes
- Sustained traffic loads beyond 'normal' from each source device are considered suspect and marked as Scavenger
- **First order anomaly detection**—no direct action taken

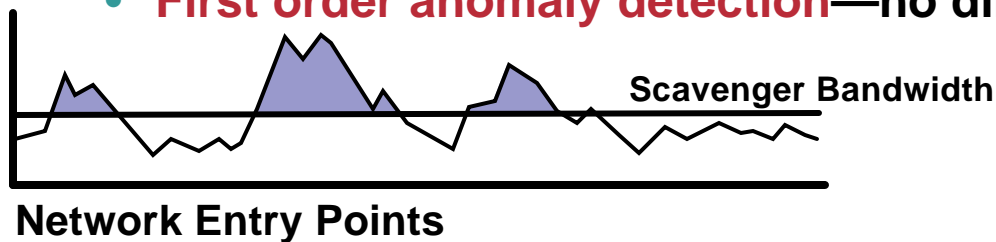

- During '**abnormal**' worm traffic conditions traffic marked as Scavenger is aggressively dropped —**second order detection**
- Priority queuing ensuring low latency and jitter for VoIP
- Stations not generating abnormal traffic volumes continue to receive network service

- During '**normal**' traffic conditions network is operating within designed capacity

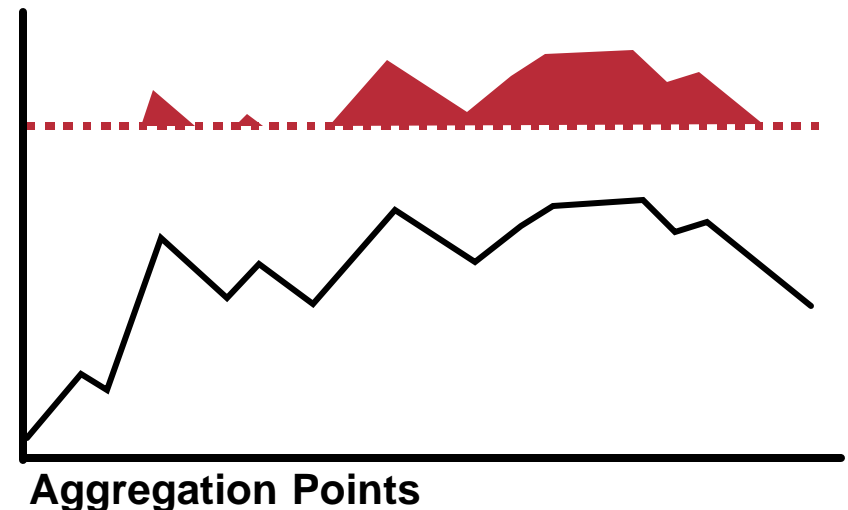

Mitigating the Impact: Scavenger-Class QoS

Scavenger Throttled Back

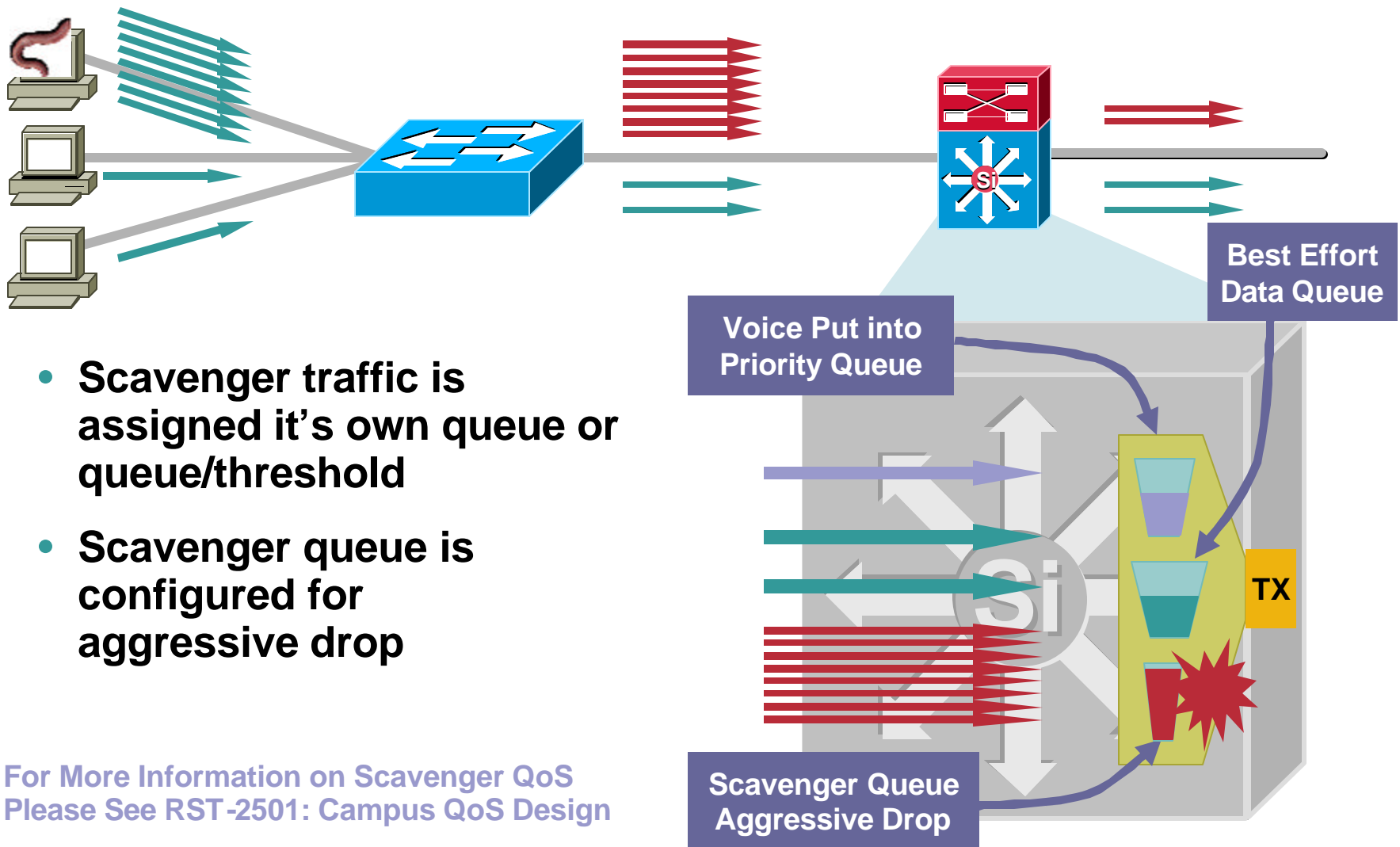

Catalyst Cisco Express Forwarding

Before CEF...Flow-Based Switching

- Nimda, Slammer, Witty and similar worms send packets to a very large number of random addresses looking for vulnerable end systems to attack
- Flow/Prefix-based switching is limited by the ability of the CPU to setup initial flows
- Flow/Prefix-based HW caches may overflow when an abnormally high number of flows established
- Ability of CPU to process control plane traffic (EIGRP, OSPF, BPDU) suffers when flow rate is abnormally high

First Packet in Flow Switched in Software

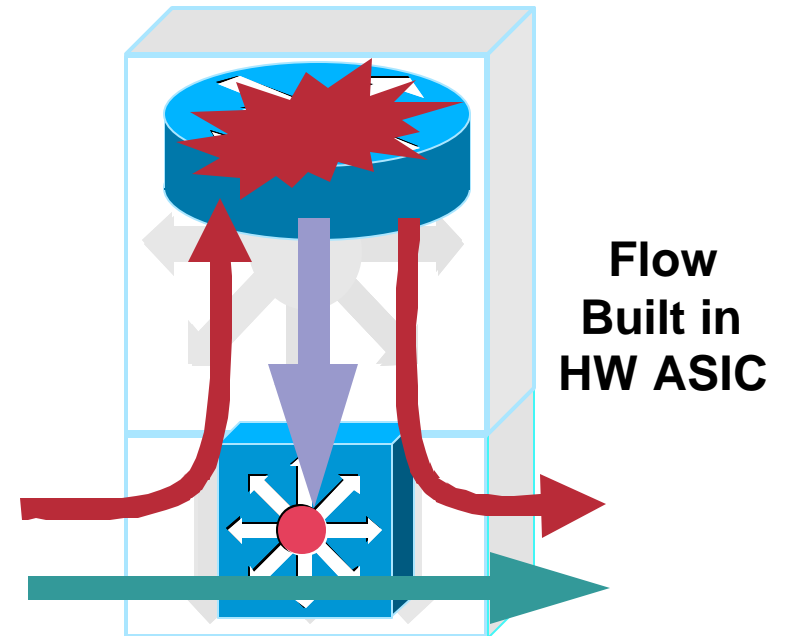

Subsequent Packets Switched in HW ASIC

Catalyst Cisco Express Forwarding

CEF: Topology-Based Switching

Cisco.com

- Route processor builds a Forwarding Information Base (FIB) calculated based on routing table entries, not traffic flows
- Hardware forwarding of first packet in each flow, whether there are one or **one million** of new flows
- Control plane unburdened by traffic forwarding—dedicated to protocol processing
- CEF protects campus switches from the abnormal worm traffic behavior

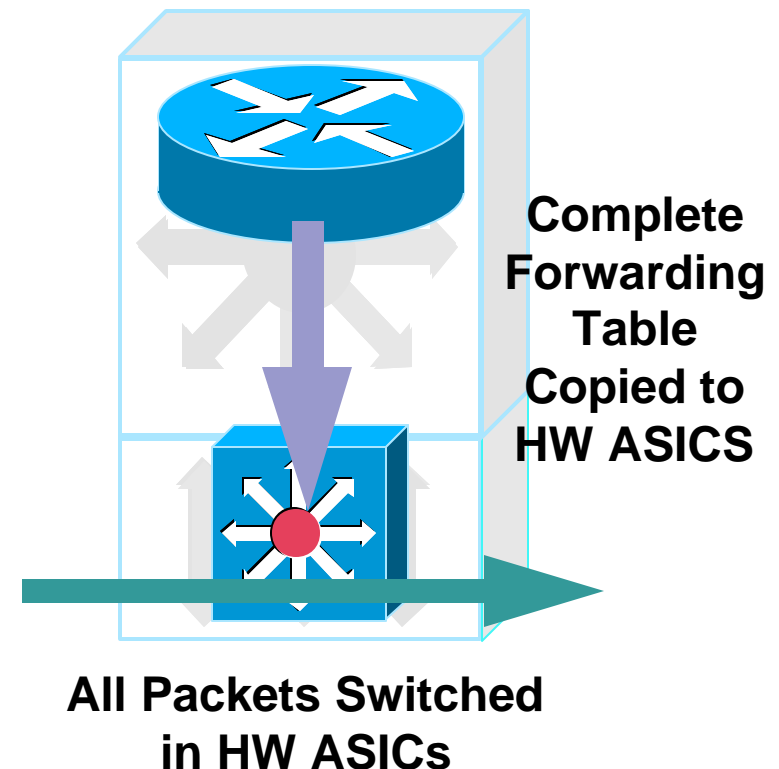

Mitigating the Impact: CEF

Worm Propagation Impacts Stability

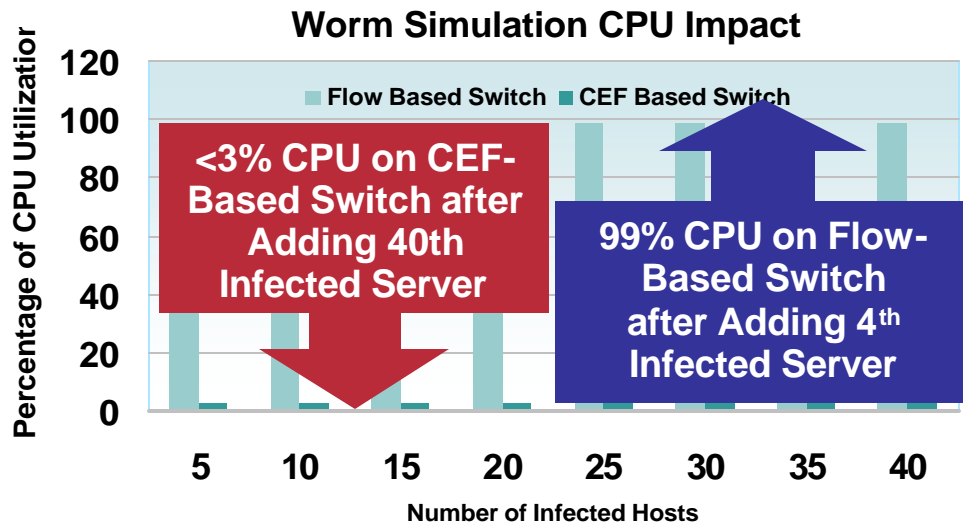

- Aggressive scanning of network by worm will overload flow-based switching
- CPU resources consumed and unable to process BPDU and routing updates
- High CPU results in network instability
- **No traffic loss with CEF**
- Catalyst 6500 Sup720 and Sup2, Catalyst 4500 Sup IV and SupII+, Catalyst 3x50 all use HW CEF

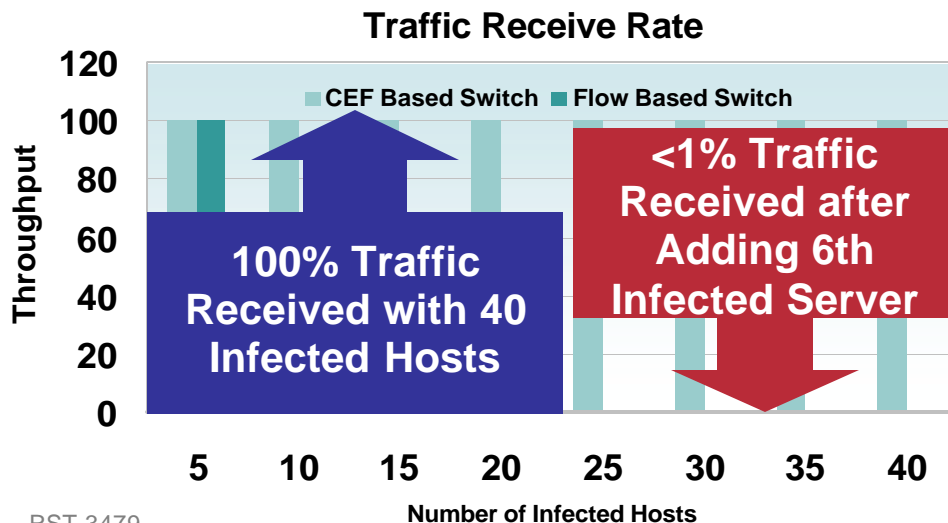

DoS Protection: Control Plane Protection

Catalyst 3750, 4500 and 6500

Cisco.com

- **CEF protects against system overload due to flow flooding**
- **System CPU still has to be able to process certain traffic**
 - BPDUs, CDP, EIGRP, OSPF,...
 - Telnet, SSH, SNMP,...
 - ARP, ICMP, IGMP,...
- **System needs to provide throttling on CPU-bound traffic**
 - Hardware Rate Limiters and CPU queuing
 - Hardware and Software Control Plane Policing (CoPP)

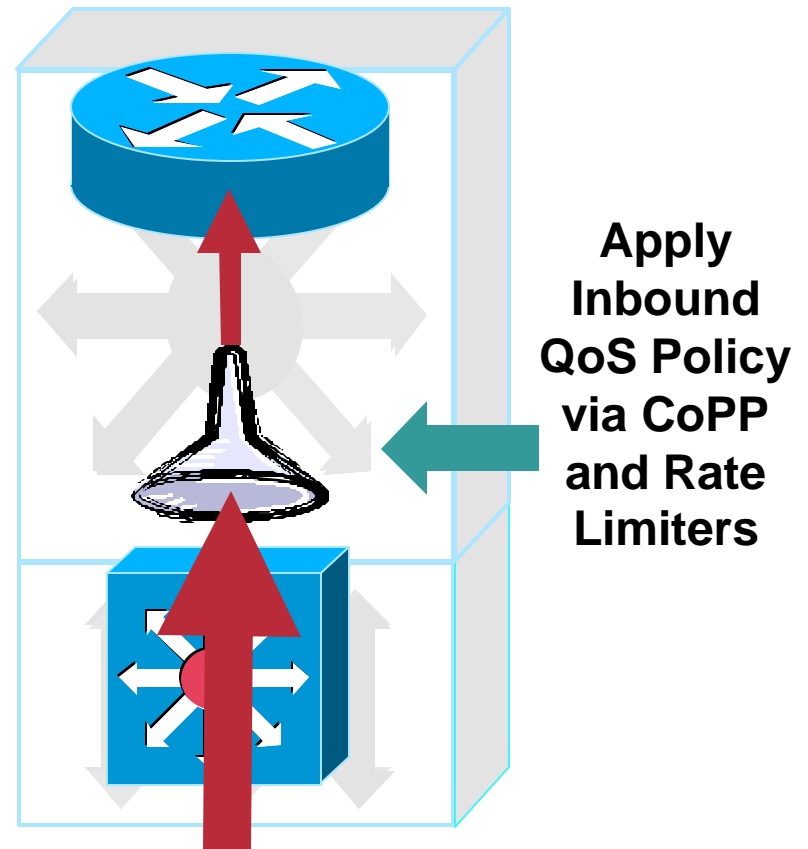

DoS Protection: Control Plane Protection

Catalyst 6500 Rate Limiting and CoPP

Cisco.com

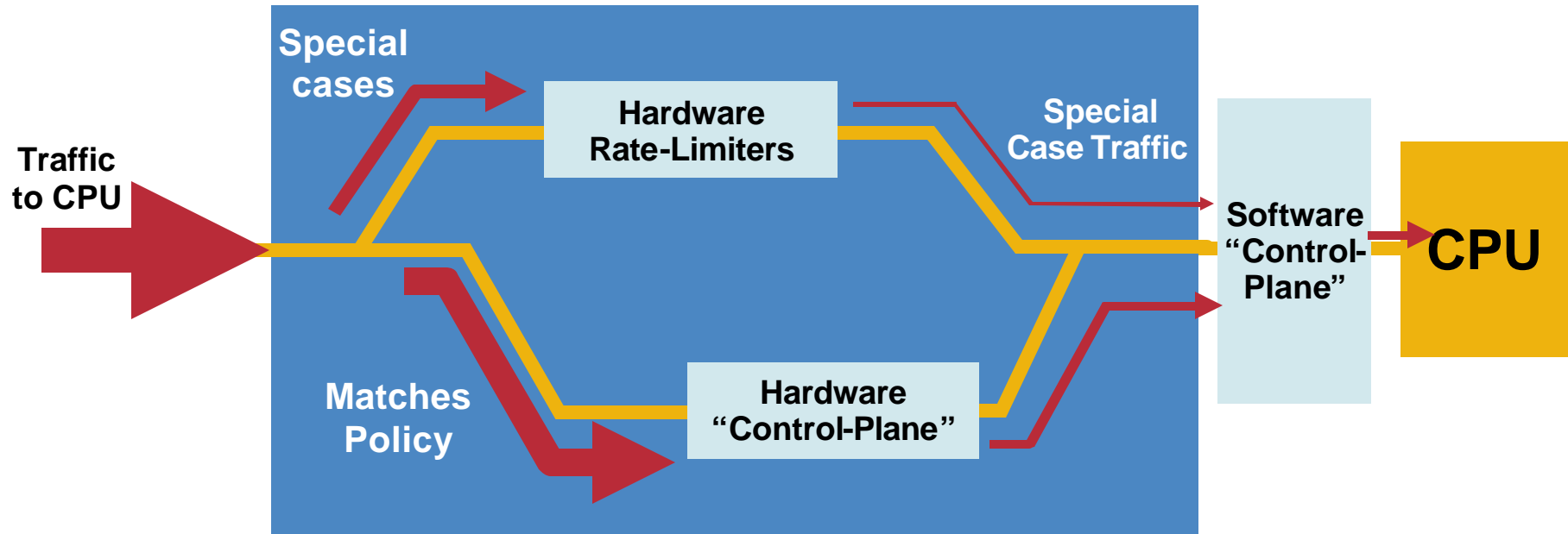

- **Ten Hardware Rate Limiters in 6500 Sup720 (eight are configurable, two reserved)**
 - Unicast Rate Limiters (CEF Receive, Glean, IP Options,...)
 - Multicast Rate Limiters (Multicast FIB Miss, Partial Shortcut,...)
 - Layer 2 Rate Limiters (PDU, L2PT)
 - General Rate Limiters (MTU Failure, TTL <= 1)
- **Traffic that matches a configured Rate Limiter bypasses HW CoPP**

DoS Protection: Control Plane Protection

Rate Limiting and CoPP Configuration

Cisco.com

- **Must enable QoS globally, otherwise, CoPP is performed in software only**
- **Define ACLs to match traffic**
Permit means traffic will belong to class, deny means fall through
- **Define class-maps**
Use “match” statements to identify traffic associated with the class
- **Define policy-map and associate classes and actions to it**
Policing is only supported action
- **Tie the policy-map to the control-plane interface**

! Partial Sample Config

```
mls rate-limit multicast ipv4 partial 1000 100
mls rate-limit all ttl-failure 1000 10

mls qos

ip access-list extended CPP-MANAGEMENT
 remark Remote management
 permit tcp any any eq SSH
 permit tcp any eq 23 any
 permit tcp any any eq 23

class-map match-all CPP-MANAGEMENT
 description Important traffic, eg management
 match access-group name important

policy-map copp
 description Control plane policing policy
 class CPP-MANAGEMENT
  police 500000 12800 12800 conform-action
  transmit exceed-action drop

control-plane
 service-policy input copp
```

Deployment Guide White Paper:

www.cisco.com/en/US/products/sw/iosswrel/ps1838/products_white_paper09186a0080211f39.shtml

DoS Protection: Control Plane Protection

Catalyst 4500 CPU Queue Scheduling and CoPP

Cisco.com

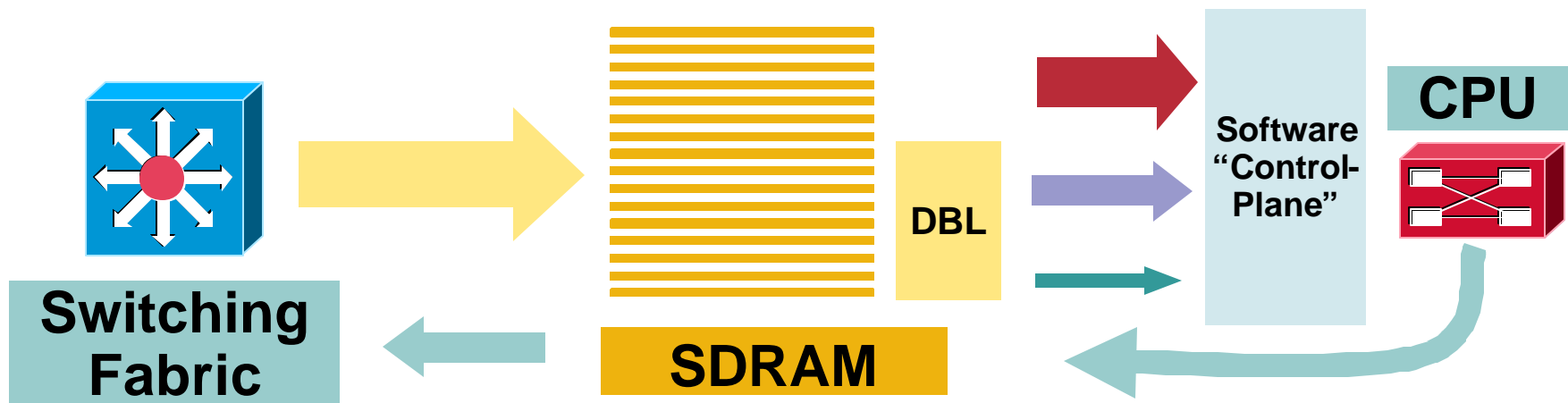

- 16 distinct inbound queues from switching fabric serviced by CPU using a weighted RR scheduling prioritizing control plane packets (e.g., BPDUs)
- Dynamic Buffer Limiting (DBL) also performed on CPU queues

```
4507-SupIV#show platform cpu packet driver
Queue          rxTail   received  all  guar  allJ  gurJ   rxDrops  rxDelays
0  Esmpp      62B26C0  522275197  99  100   0    5        0         0
1  Control    62B2BA0  22814109   595 600   0    5        0         0
...
15 MTU Failure 62B848C           0  102  102   0    5        0         0
```

Mitigating the Impact: CoPP

CoPP and Rate Limiters Compliment CEF

- Multiple concurrent attacks (Multicast TTL=1, Multicast Partial Shortcuts, Unicast IP Options, Unicast Fragments to Receive adjacency, Unicast TCP SYN Flood to Receive Adjacency)
- CPU kept within acceptable bounds with no loss of mission critical traffic

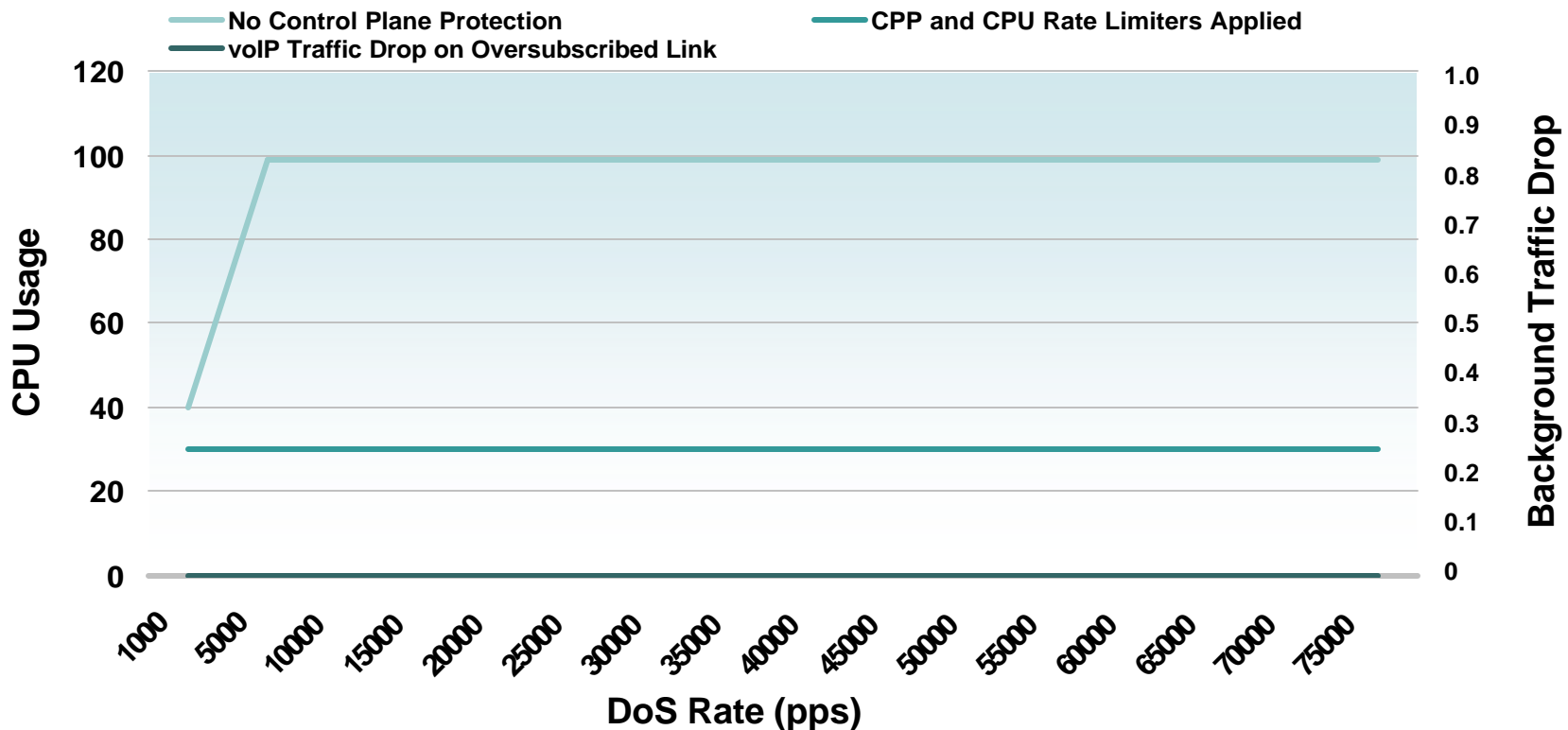

Finding the Worm: Sink Hole Routers

Monitoring for Network Worms

- Sink hole router sources a default route (0.0.0.0) into core of network
- All traffic with a destination address not in the Enterprise network is sent to the sink hole
- Monitor inbound traffic to the sinkhole via ACLs, ip accounting or Netflow
- Net mgmt scripts look for common sources sending to random addresses
- Does not work when default routing to Internet

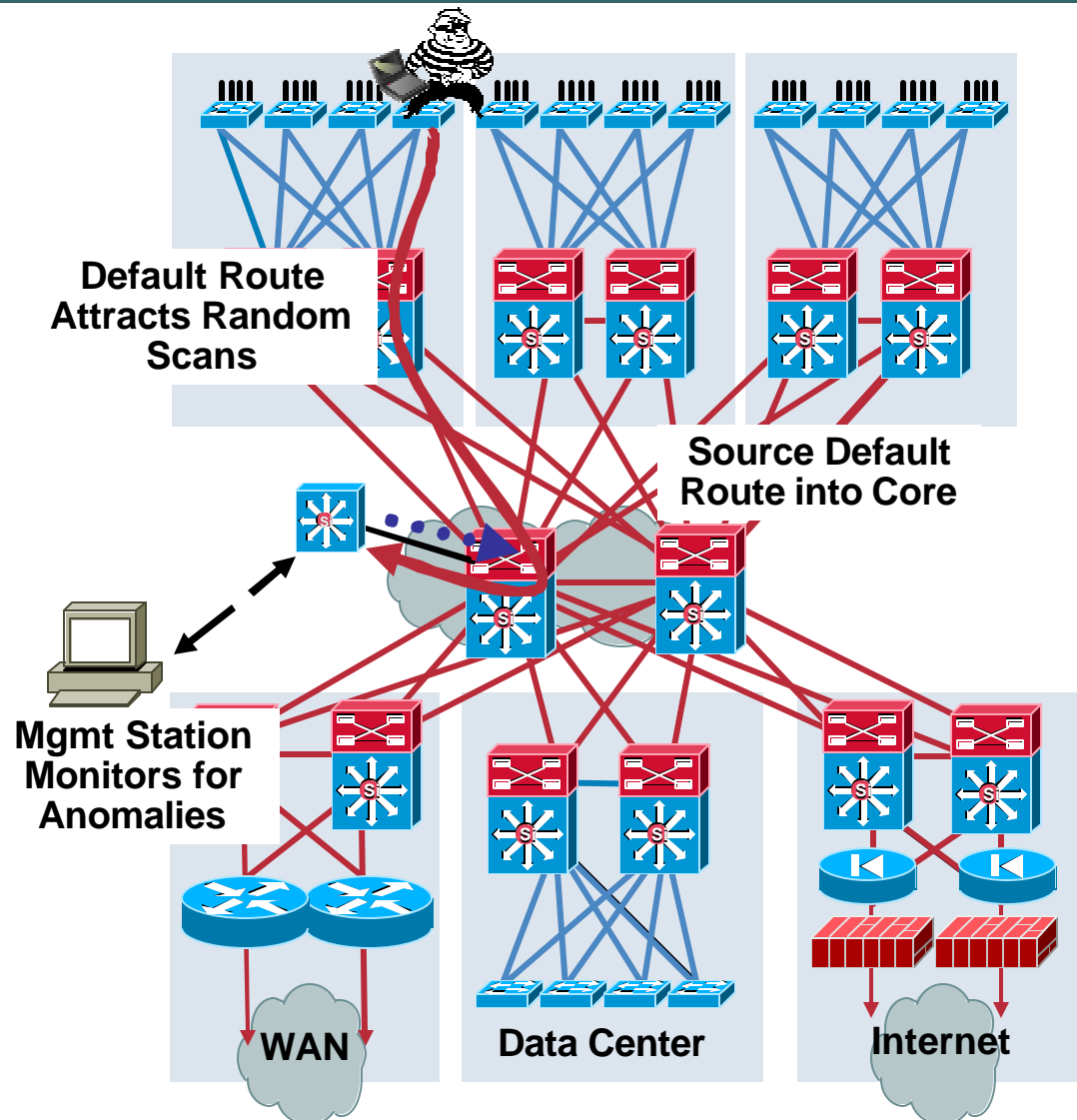

Finding the Worm: NetFlow

Scalable Monitoring for Network Worms

- Sink hole routers do not detect intelligent scanning worms
- Netflow provides a scalable mechanism to monitor for worms throughout the network
- Enable Netflow as close to the edge of the network as possible in order to maximize detection accuracy

Distribution switches
WAN aggregation
Internet DMZ

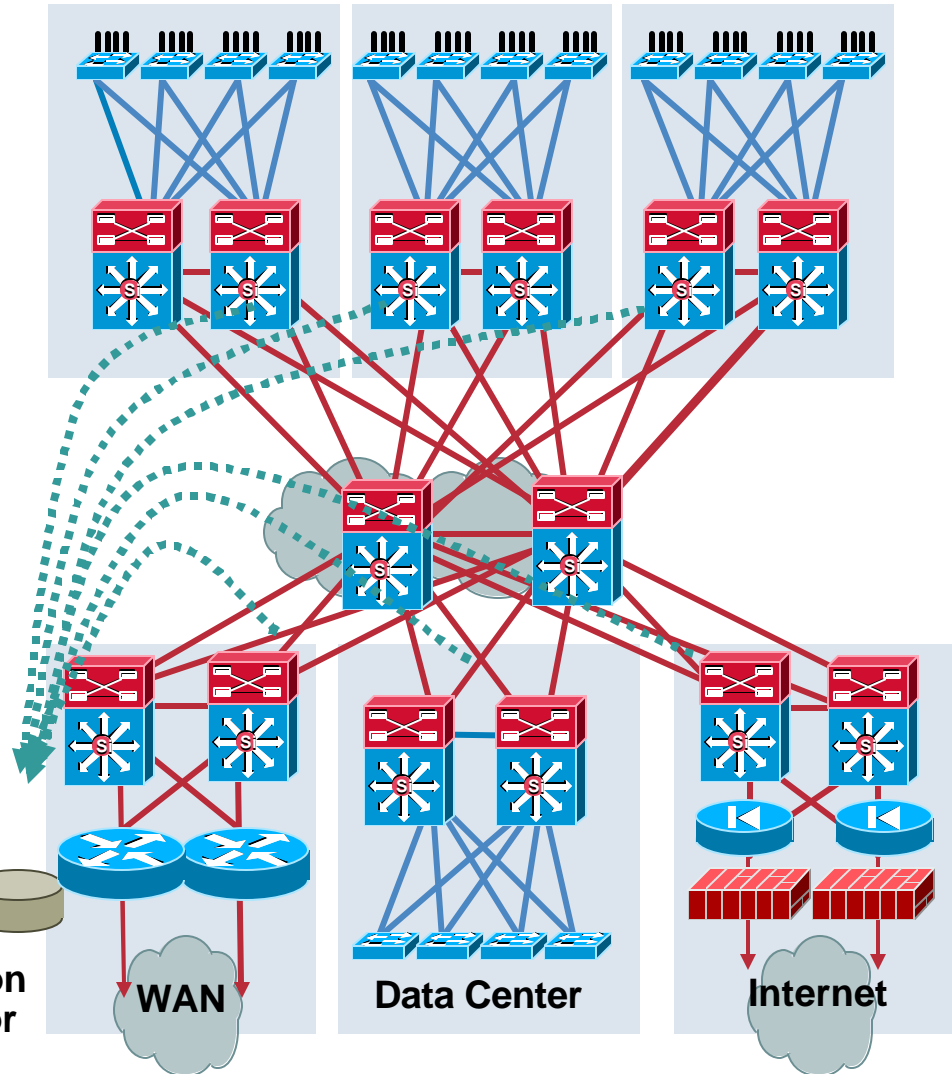
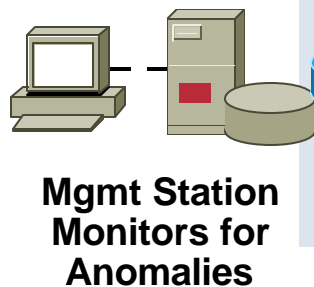

Worm Containment: Reactive

PACLs, RACLs, VACLs, and CAR

Cisco.com

- Hardware access control lists can be utilized at multiple tiers in the network
- Port ACLs allow L3/L4 ACLs to be applied to a L2 port
- Utilize a PACL to block specific worm traffic at network edge
- Utilize VLAN ACLs to block specific worm traffic over a VLAN
- Utilize router ACLs at L3 choke points to block specific worm traffic
- CAR can be used to throttle traffic to destinations under attack (DDoS) on Cisco IOS-based routers

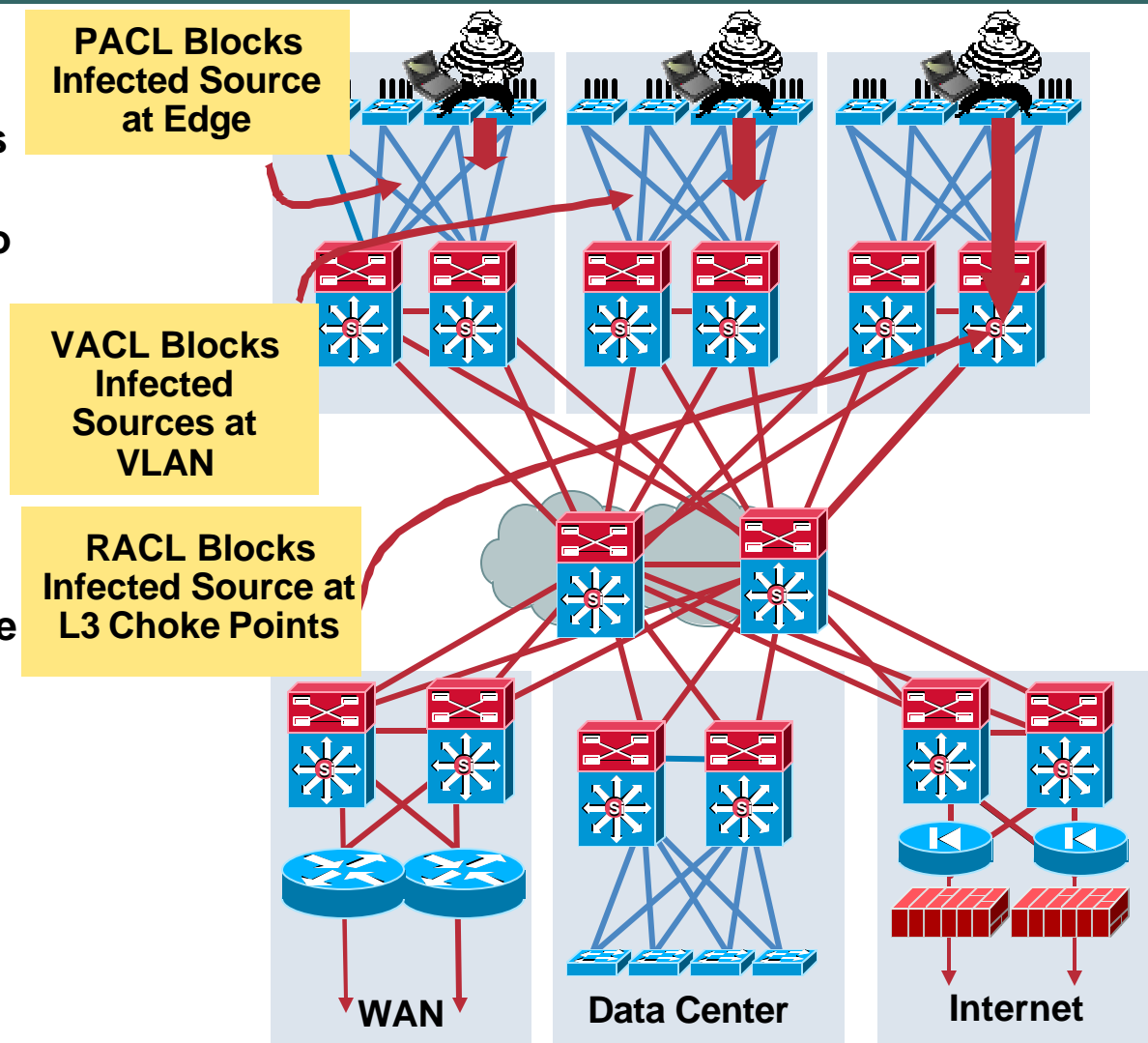

Worm Containment: Block Infected Sources

Triggered uRPF Blackholes

Cisco.com

- Need a scalable method to rapidly block traffic **from** infected sources (Worm)
- Need a scalable method to rapidly block traffic **to** destinations under attack (DDoS)
- Triggered uRPF Blackhole Routers will do both
- Using iBGP push message to choke points to discard the attack packets
- Does NOT require to use BGP as your routing protocol
- Recommended **Sup720B** to support; require Sup720

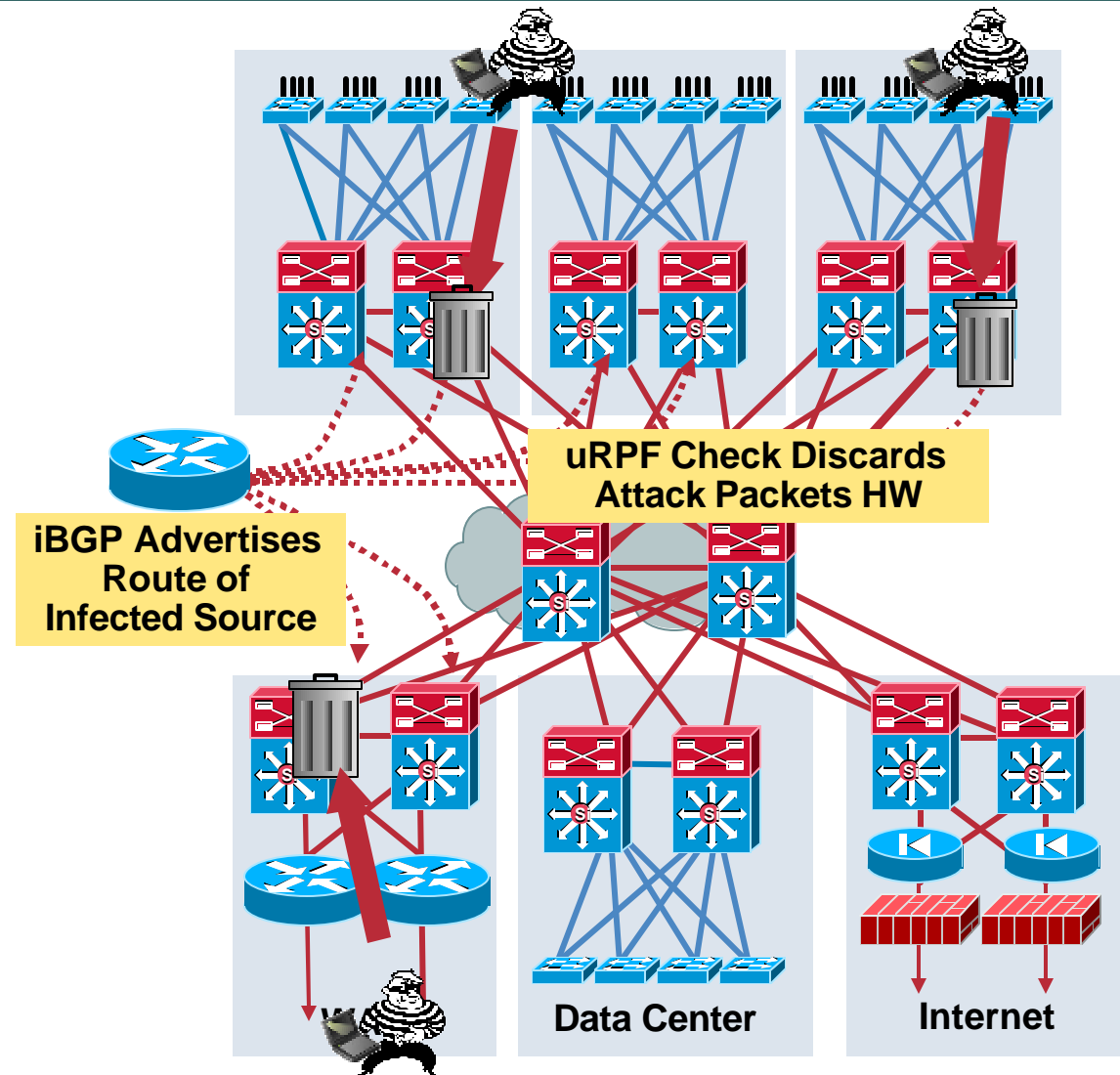

Blackholing Infected Sources

Unicast RPF Loose Check

- **Loose uRPF checks if route is found in the Forwarding Information Base (FIB)**
 - If not in FIB, drop the packet
 - If equal to Null0, drop the packet
- **Using iBGP insert a route for infected sources that point to Null0**
- **Activate loose uRPF on downstream stream switch ports**
- **Choke point switch drops packets with infected source addresses**

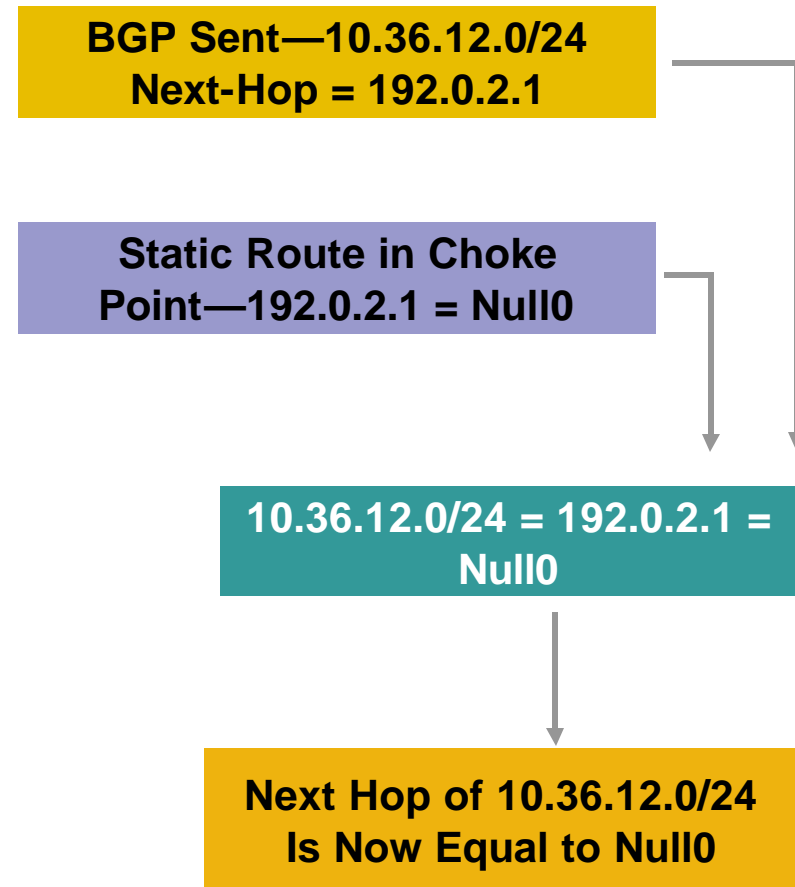

Does It Work?

Voice Survives the Worm

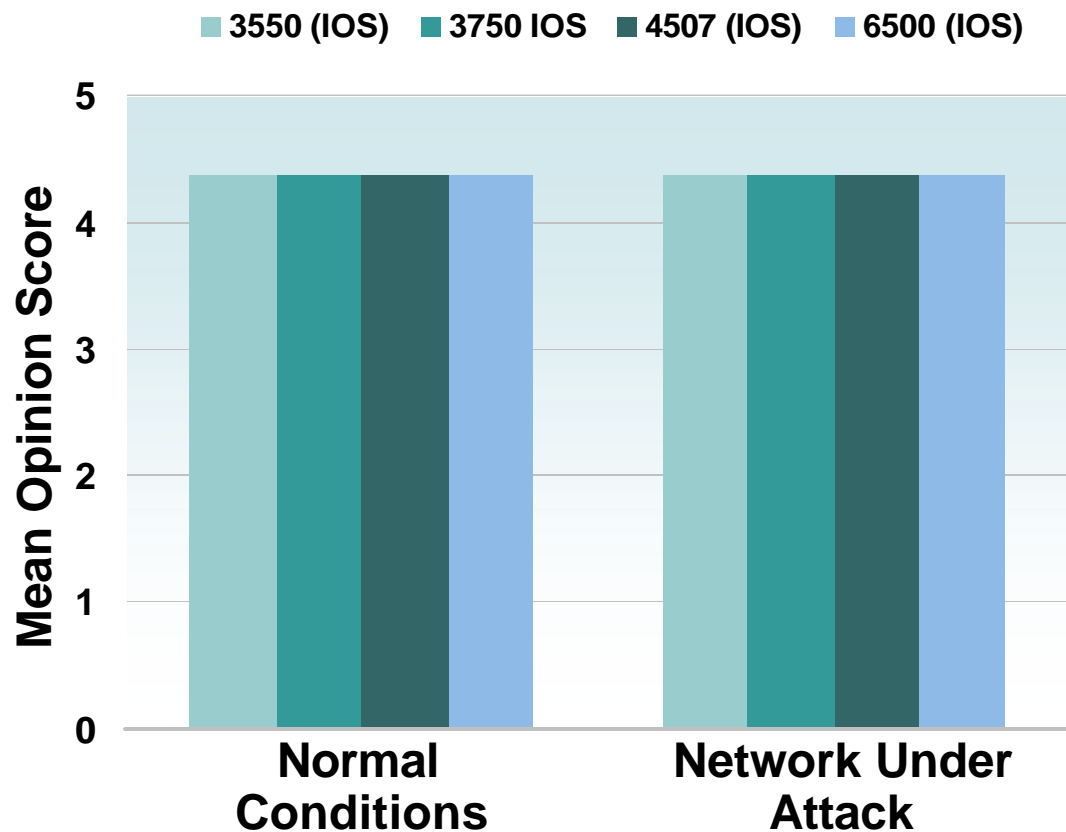

- **90 P4 GigE servers**
- **Simultaneous attacks**
 - Simulated Slammer
 - Macof—L2 DoS
 - Smurf—L3 DoS
- **6500 with Sup720a in the distribution**
- **Network remained stable**
- **Mean opinion score for G.711 voice flows unchanged from normal conditions**

Agenda

- **Foundational Design Review**
- **Convergence—IP Communications**
- **Wireless LAN and Wireless Mobility**
- **High Availability**
 - Alternatives to STP
 - Device HA (NSF/SSO and Stackwise)
 - Resilient Network Design
- **Segmentation and Virtualization**
 - Access Control (IBNS and NAC)
 - Segmentation
- **Questions and Answers**

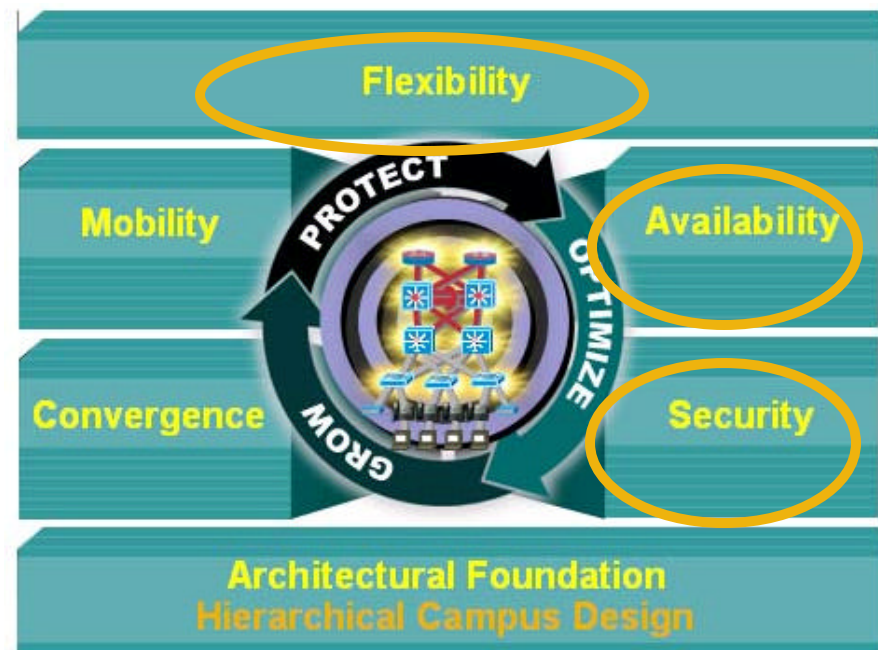

IBNS (802.1x) and NAC

Access and Policy Control

- **Identity-Based Networking Services (IBNS)**
Identifies and authenticates the user or device on the network and ensures access to correct network resources
- **Network Access Control (NAC)**
Performs **posture validation** to ensure that machines not compliant with software posture, and therefore vulnerable to infection, can be isolated to a segment of the network where remediation can take place
- 802.1x provides port-based access control and operates at L2
- NAC provides posture assessment and device containment at L3 or L2
- **Complimentary functions**

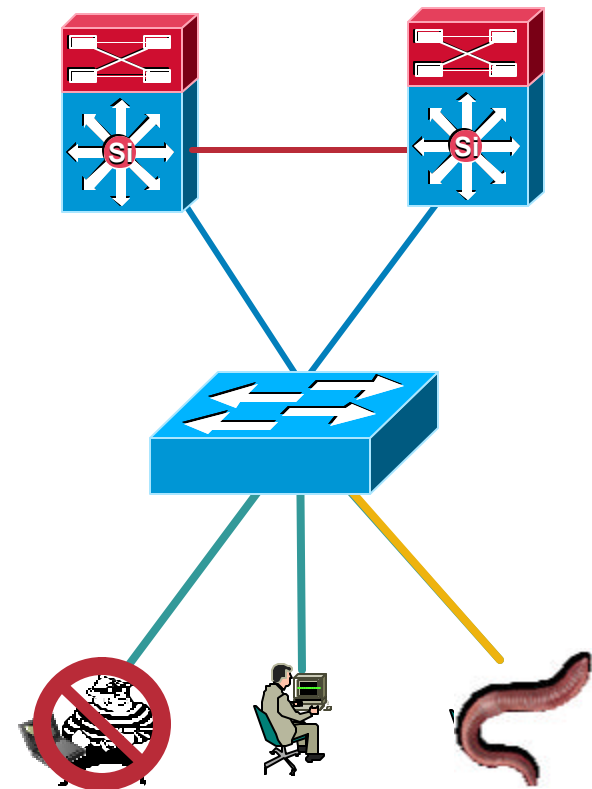

Edge Access Control

802.1x and NAC Operation

EAP, EAPoL, RADIUS, and HCAP

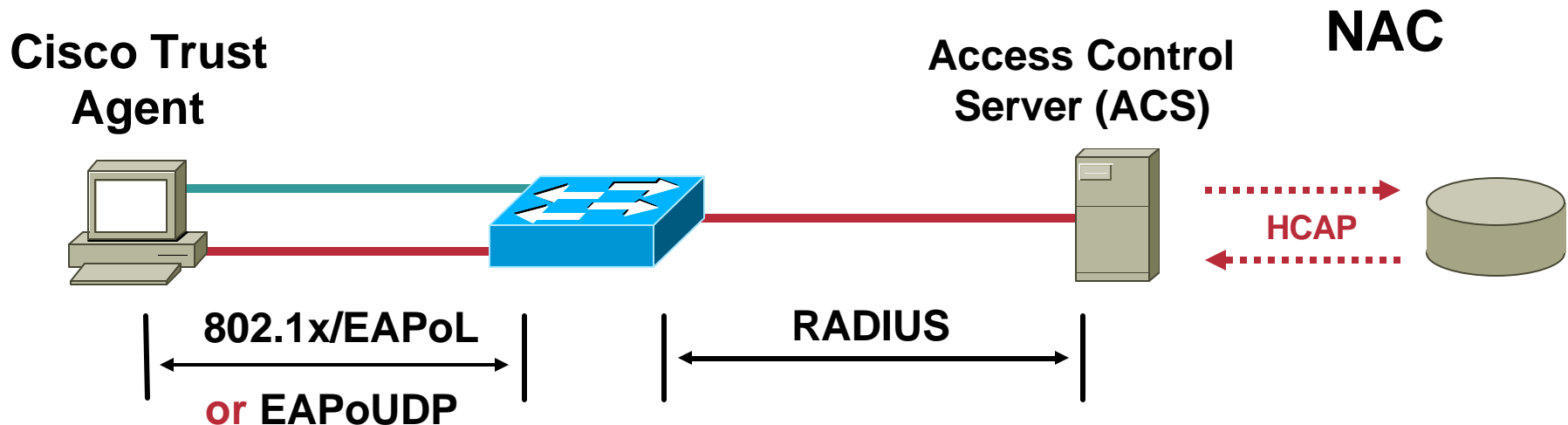
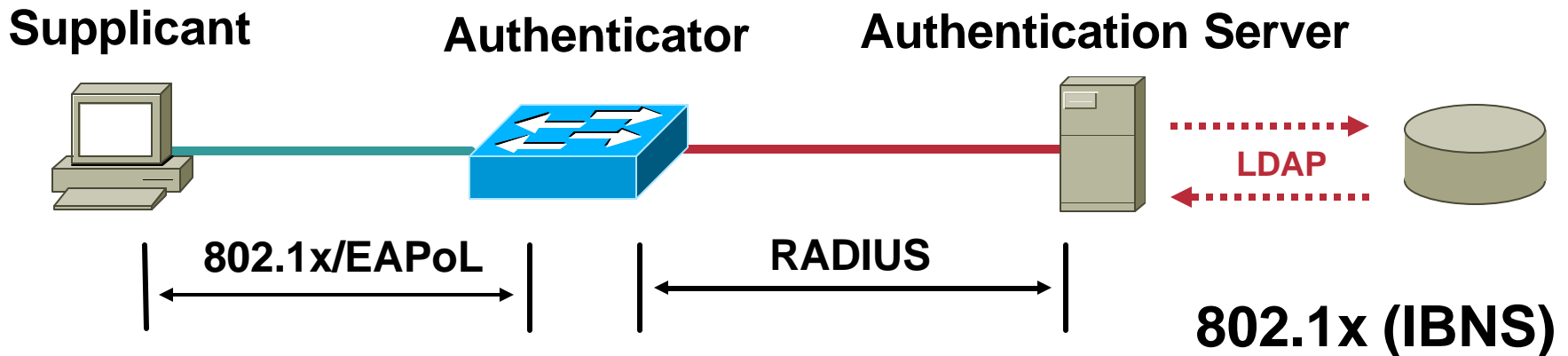

For More Discussion on IBNS and NAC Please See—SEC2005

802.1x Use of VLANs

VLAN Assignment and the Guest VLAN

- 802.1x defines an access method for LAN switch ports
- You can permit or deny access based on authorization behavior
- Using RADIUS AV-Pairs we can supply additional policy options for the switch port
- VLAN assignment utilizes AV-Pairs
 - [64] Tunnel-Type—"VLAN" (13)
 - [65] Tunnel-Medium-Type—"802" (6)
 - [81] Tunnel-Private-Group-ID—<VLAN name>
- In the absence of an EAPoL response from the client the switch can assign the port to a locally configured 'Guest' or default VLAN

VLAN Assignment

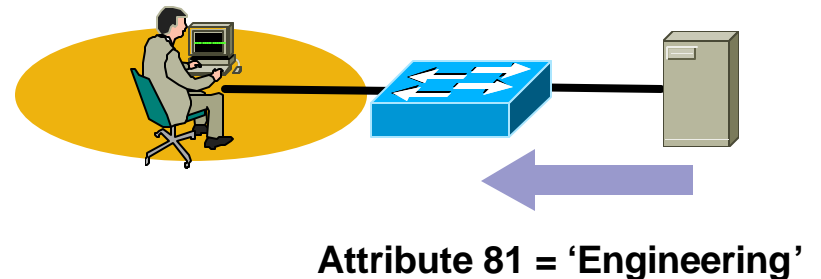

Guest VLAN

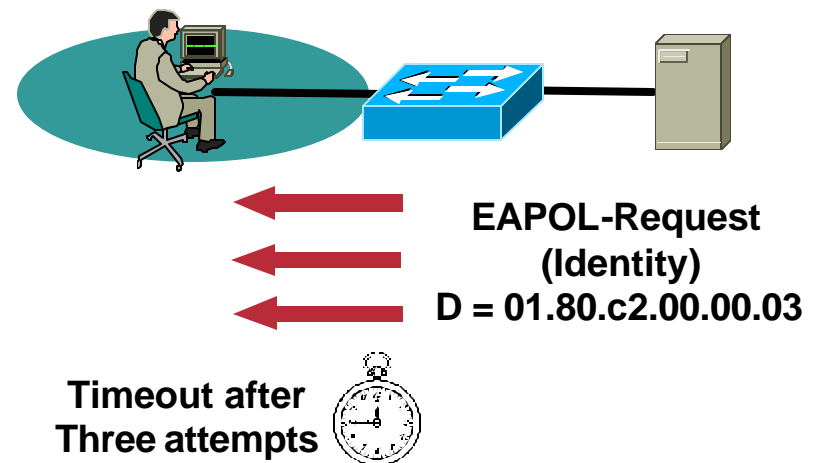

802.1x and NAC

Gateway IP (NAC Version1)

- NAC posture assessment at the first Layer 3 hop (default GW)
- Cisco IOS 'Intercept ACL' will intercept interesting traffic generated by end station and initiate an EAP/UDP session
- Based on response from RADIUS/Policy server will apply an ACL to permit or control access
- If used 802.1x authentication occurs **prior and independently** of NAC posture assessment
- Gateway IP is not currently supported on any Catalyst Switch (Cisco IOS Router only)
- Not currently applicable to the Campus today

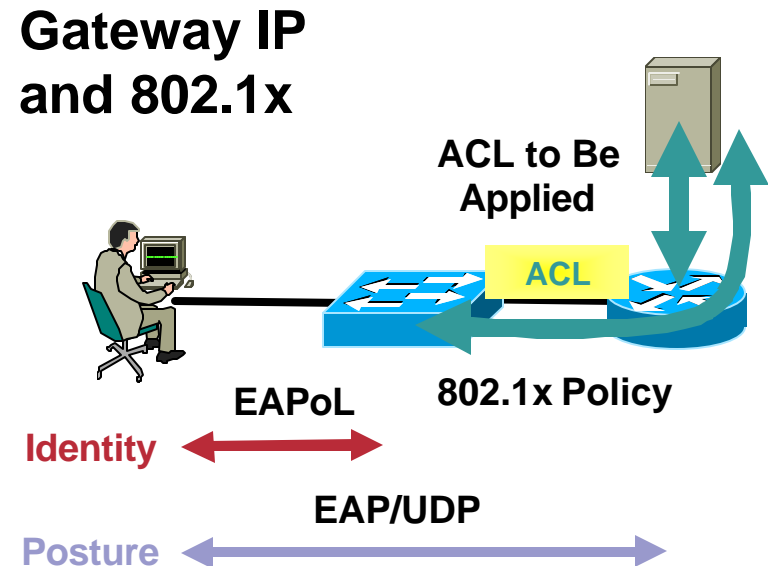
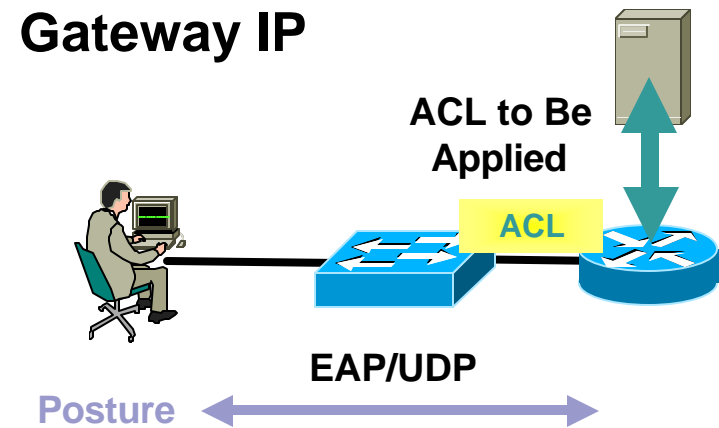

802.1x and NAC in the Campus

LAN Port dot1x and LAN Port IP

- NAC posture assessment at the first Layer 2 hop (switch port)
- LAN Port IP triggers an EAP posture session when first **ARP** is received on a port or **DHCP snooping** is triggered

Applies posture policy via a Port ACL

Assumes innocent until proven guilty

- LAN Port 802.1x supplies both identity credentials along with posture data during dot1x login

Applies posture policy via VLAN assignment—Remediation VLAN

Assumes guilty until proven innocent

LAN Port IP

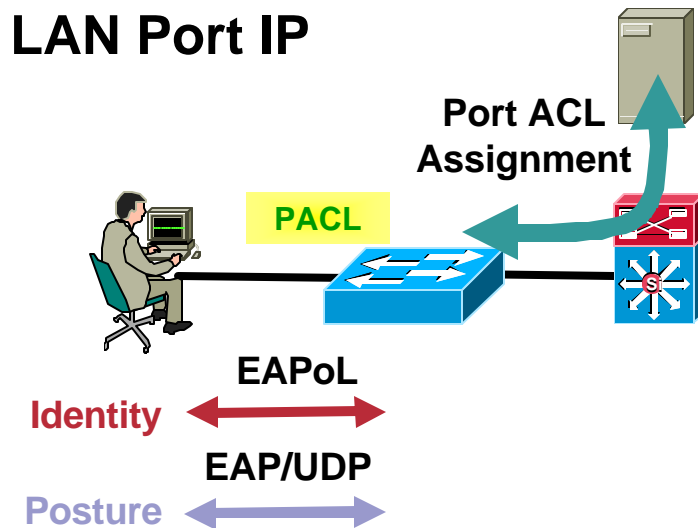

LAN Port 802.1x

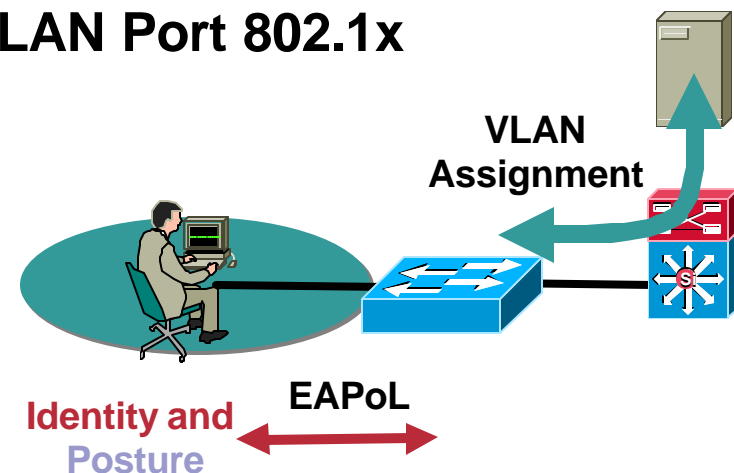

Campus Design Considerations for 802.1x

MAC-Auth and Failed Authentication VLAN

- **MAC-Auth**

Provides a supplementary authentication based on MAC address

After timeout of EAPoL MAC address is proxied to ACS to provide credentials for authentication

Requires 6500 CatOS 8.5(1)

- **Authentication Fail VLAN**

Allows end devices without valid credentials to be assigned to a 'Guest' VLAN

Assigns devices to Auth-Failed VLAN after three consecutive login failures

Requires 6500 CatOS 8.4(1)

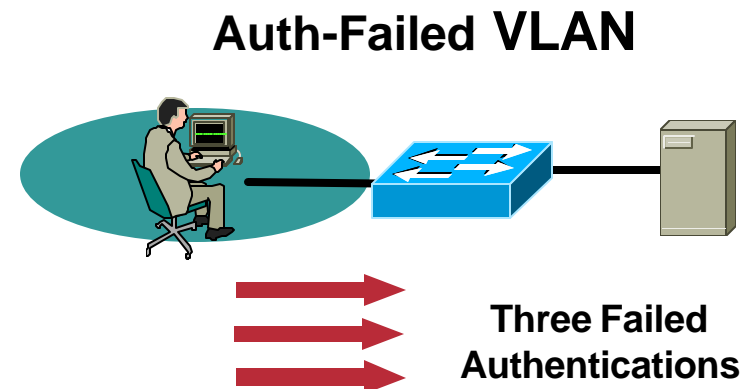
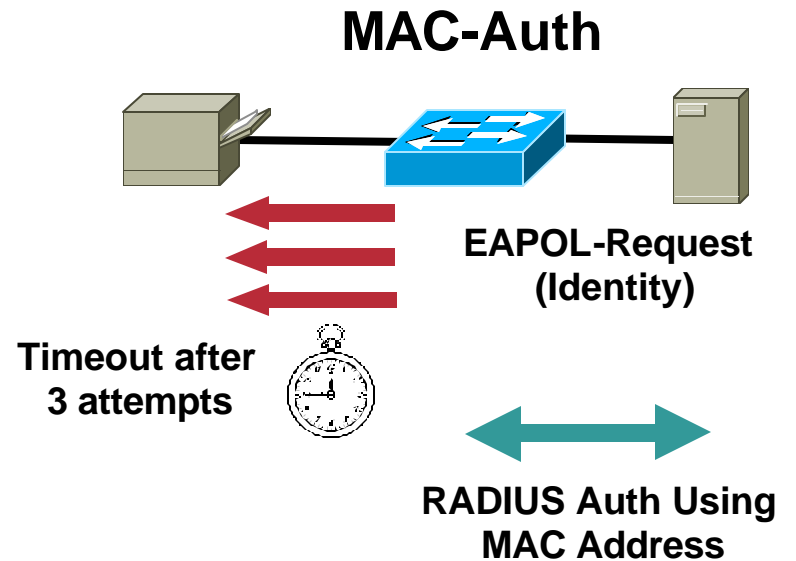

Sample NAC/IBNS switch config

802.1x, NAC, Guest, MAC-Auth and Auth Fail

Cisco.com

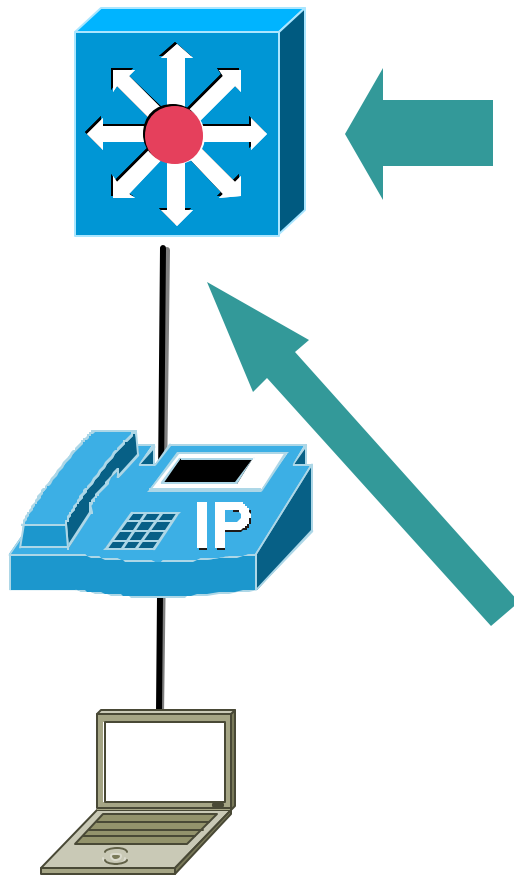

CatOS Global Configuration

```
set dot1x system-auth-control enable
set radius server 10.1.125.1
set radius key cisco123
```

IOS Global Configuration

```
radius-server host 10.1.125.1
radius-server key cisco123
aaa new-model
aaa authentication dot1x default group radius
aaa authorization default group radius
dot1x system-auth-control
```

CatOS Port Configuration

```
set port dot1x 3/1-48 port-control auto
set port dot1x 3/1-48 guest-vlan 250
set port dot1x 3/1-48 auth-failed-vlan 251
set port mac-auth-bypass 3/1-48 enable
```

IOS Per-Port configuration

```
int range fa3/1 - 48
dot1x port-control auto
dot1x guest-vlan 250
```

Campus Design Considerations for 802.1x

VTP, CDP and 802.1x Interaction

Cisco.com

- VLAN assignment utilizes a string field in the RADIUS attributes to select the VLAN
- This VLAN name should map to a unique VLAN on each access switch
- VTP database will be different on all switches
- Switches need to use either VTP transparent or off
- Switch requires CDP detection of phone to allow phone to connect without 802.1x
- Once identified phone moved to VVID and PC completes 802.1x on the PVID

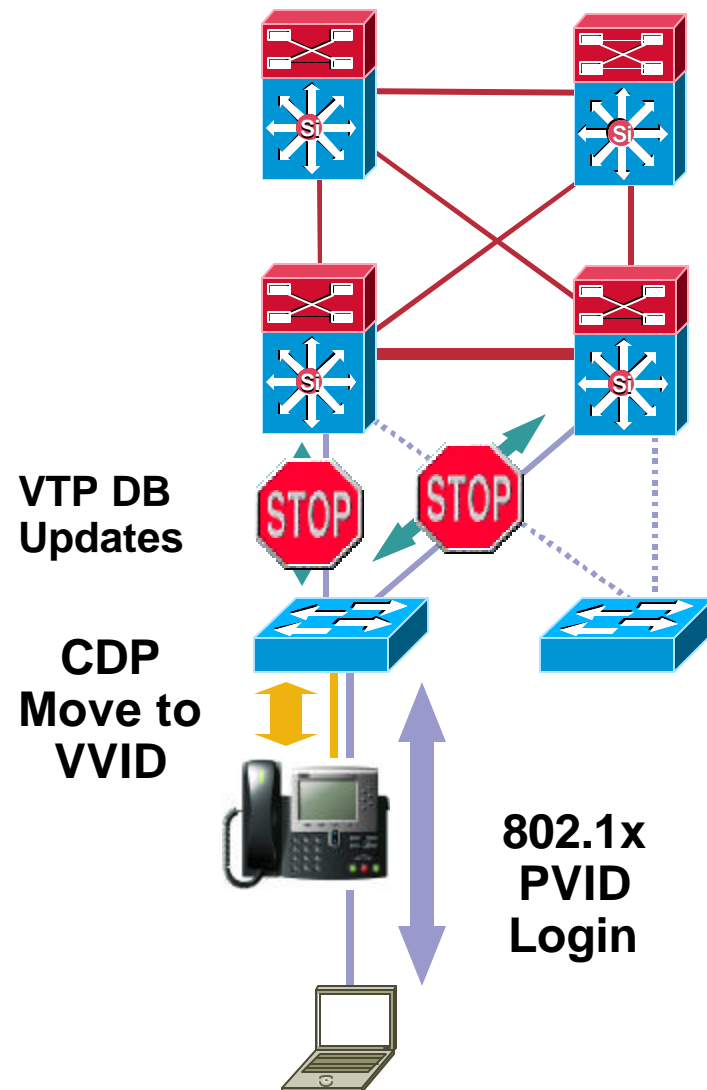

Campus Design for 802.1x and NAC

What Do I Do with Them Once I Have Them in a VLAN?

- 802.1x and NAC LAN Port 802.1x Basic both control network access based on VLAN assignment
- Once they are assigned to a specific VLAN the network infrastructure needs to keep the traffic isolated
- Potential Solutions
 - ACLs
 - PBR with GRE
 - VRF with GRE
 - VRF-Lite
 - MPLS
- All provide some form of **Network Compartmentalization**

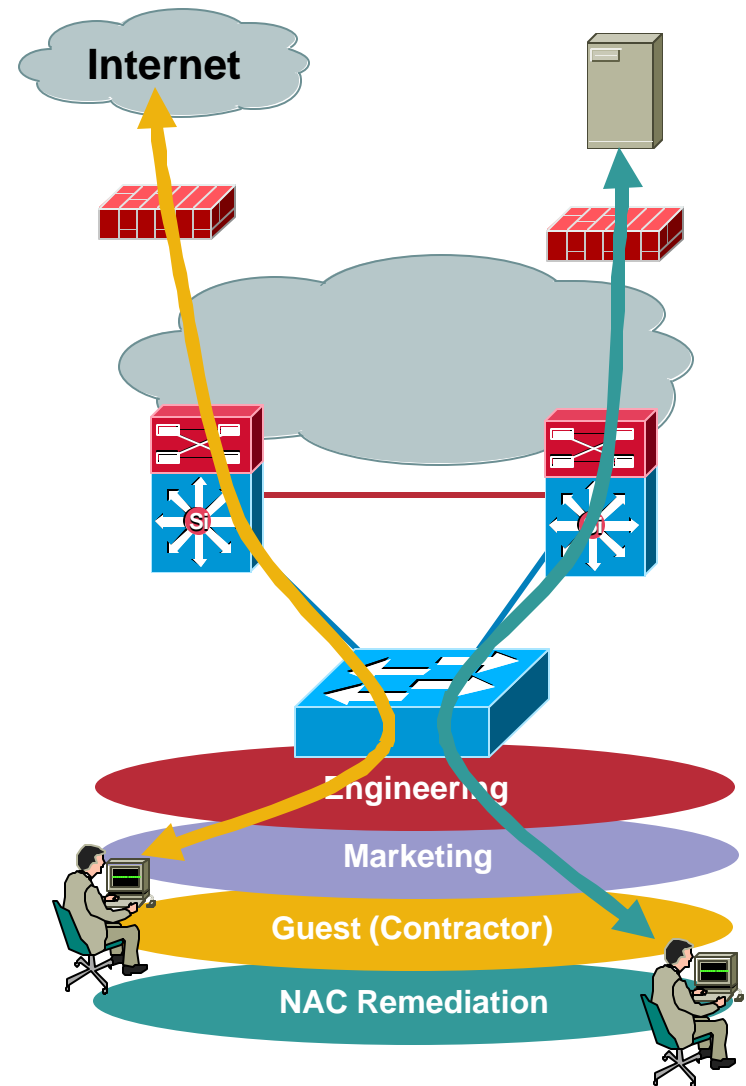

Segmentation and Virtualization

Closed User Groups with Centralized Policy

Cisco.com

- **Guest and Remediation one example of a larger problem**
- **Closed User Group creation**
 - Provides secure and independent communication over a shared infrastructure
 - Enable User Mobility
- **Centralization of policies and services**
 - Policies based on groups
 - Enhanced Manageability
- **Sharing of network intelligence/services**
 - Costly resources centrally serve all groups while maintaining privacy

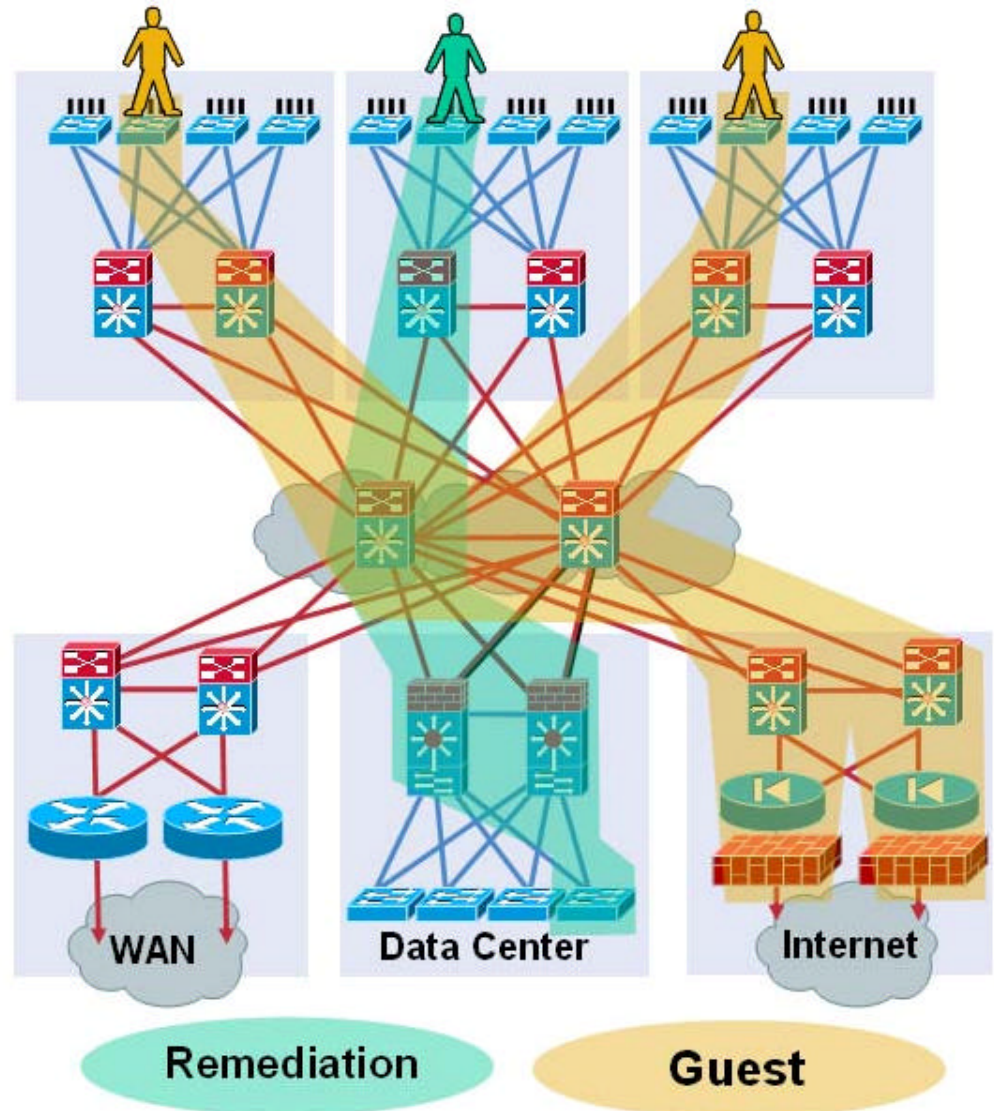

Campus Segmentation

Policy Control—ACLs

- **Restricting Guest and Remediation traffic via ACLs**
- **Pros:**
 - HW-Based Forwarding
 - Simple Initial Deployment
- **Cons:**
 - Distributed static configuration
 - ACLs provide for restriction of traffic but not for control of the forwarding path of the traffic
 - Restricts user mobility

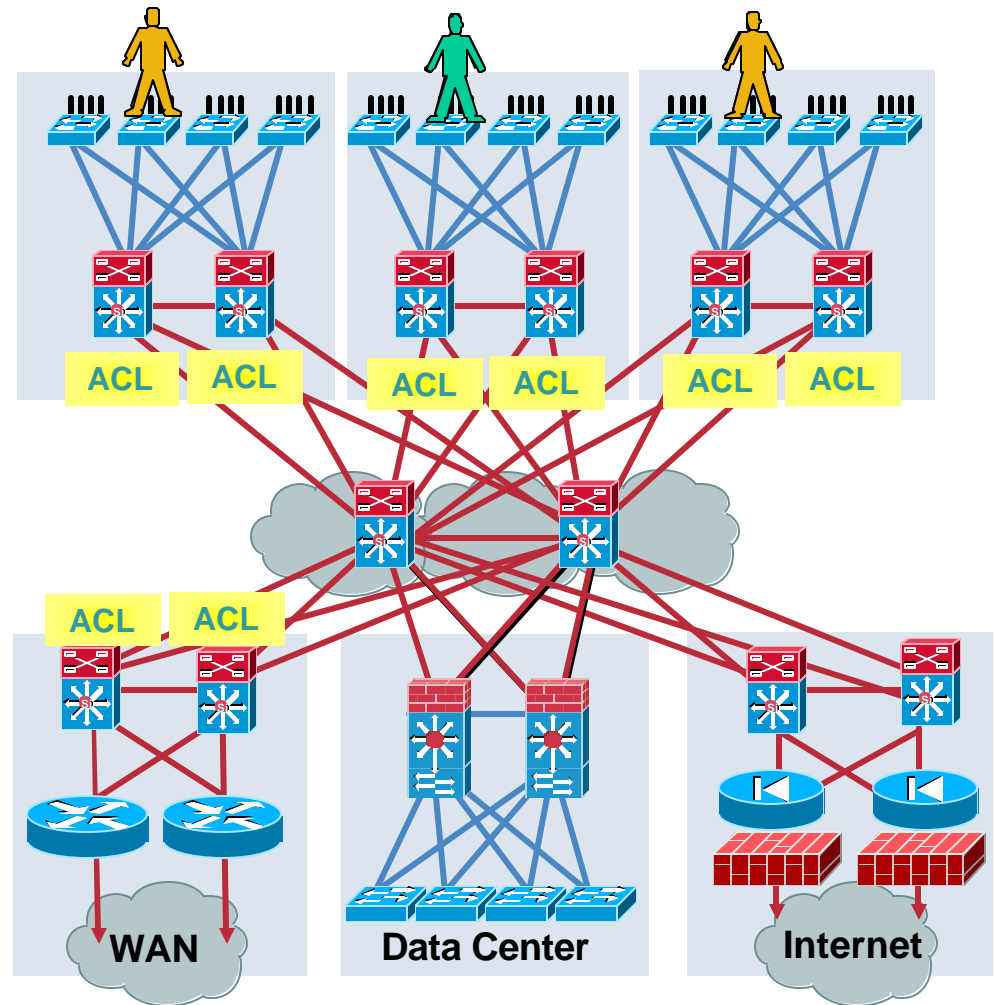

Segmentation and Virtualization

GRE and PBR Guest and Remediation

- Configure Policy-Based Routing (PBR) to route all Guest/Remediation traffic via GRE tunnels
- Forces traffic to the DMZ or Remediation Zone

```
interface Vlan250
description Guest_VLAN
ip policy route-map Guest-VLAN-to-DMZ

interface Loopback0
ip address 10.1.250.5 255.255.255.255

interface Tunnel0
ip address 10.1.250.9 255.255.255.252
tunnel source Loopback0
tunnel destination 10.1.250.10

ip access-list extended Guest-VLAN-to-DMZ
permit ip any any
route-map Guest-VLAN-to-DMZ permit 10
match ip address Guest-VLAN-to-DMZ
set interface Tunnel0
```

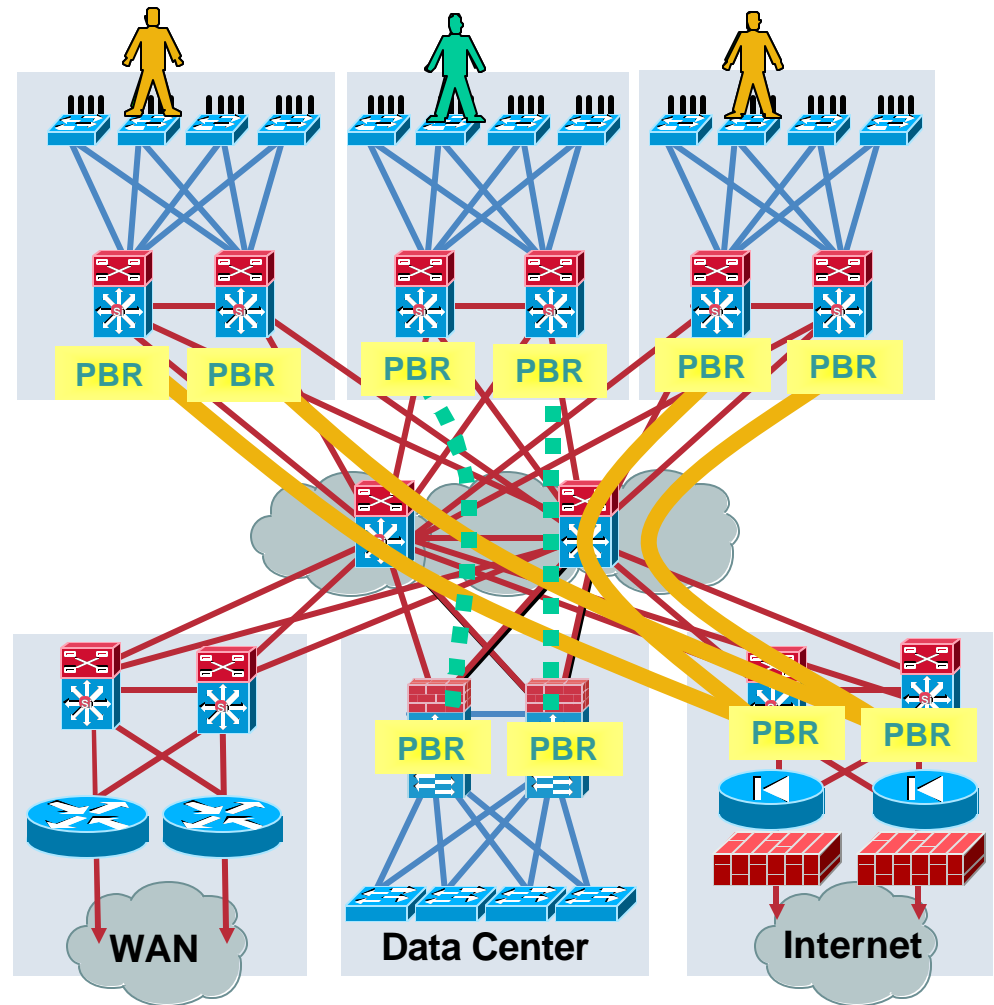

Virtualized Devices and Data Paths

VRF (Virtual Routing and Forwarding)

Cisco.com

- VRF allows for the creation of multiple logical forwarding tables
 - Distinct Routing Information Base (RIB)
 - Distinct Forwarding Information Base (FIB)
- It is possible to associate with each VRF a group of unique logical data paths, e.g.
 - 802.1q VLANs
 - GRE Tunnels
- Leverage multipoint GRE (mGRE) and Next Hop Resolution Protocol (NHRP) to ease configuration

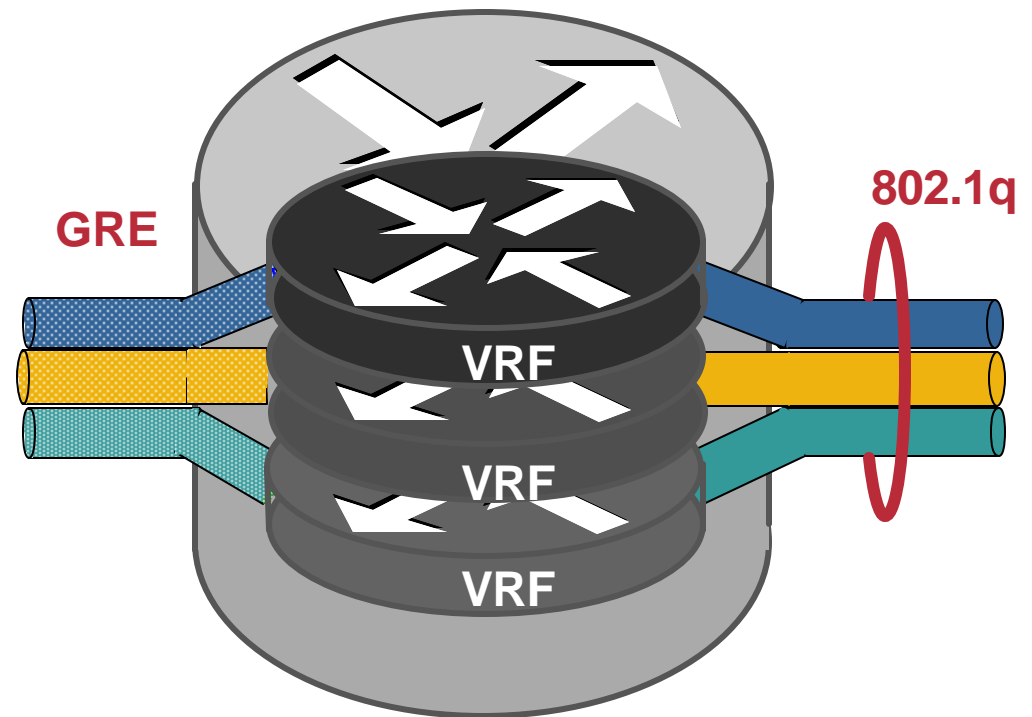

Traffic Is Routed from Each 802.1q VLAN to the Associated GRE Tunnel

Segmentation and Virtualization

GRE and VRF Guest and Remediation

- Control traffic coming from a specific VLAN to only be able to be forwarded on specific GRE tunnels
- Utilize mGRE and NHRP to simplify the configuration of the tunnels

```
ip vrf GuestAccess
rd 10:10

interface loopback100
ip address 10.1.4.3

interface tunnel 0
ip vrf forwarding GuestAccess
ip address 192.168.100.2 255.255.255.0
ip mtu 1416
ip nhrp map 192.168.100.1 10.126.100.254
ip nhrp map multicast 10.126.100.254
ip nhrp network-id 100
ip nhrp nhs 192.168.100.1
tunnel source Loopback100
tunnel destination 10.126.100.254

interface vlan 10
ip address 192.1.1.4
ip vrf forwarding GuestAccess
```

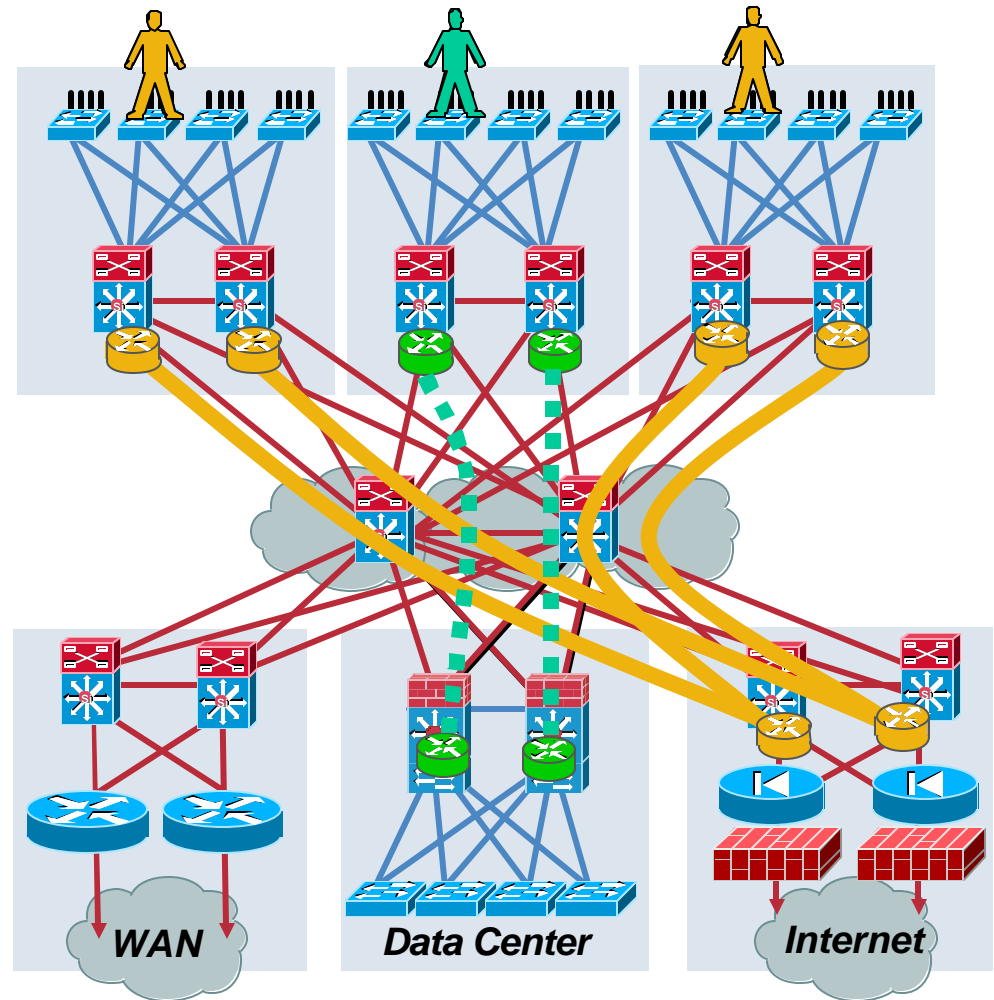

Virtualized Devices and Data Paths

End to End VRF-Lite (802.1q Virtual Links)

- VRF-Lite utilizes hop by hop 802.1q to VRF mapping to build a closed user group
- Association of VRF to VLAN is manually configured
- Each VRF Instance needs a separate IGP process (OSPF) or address family (EIGRP, RIPv2, MP-BGP)
- In this configuration Traffic is routed from each 802.1q VLAN to the associated 802.1q VLAN

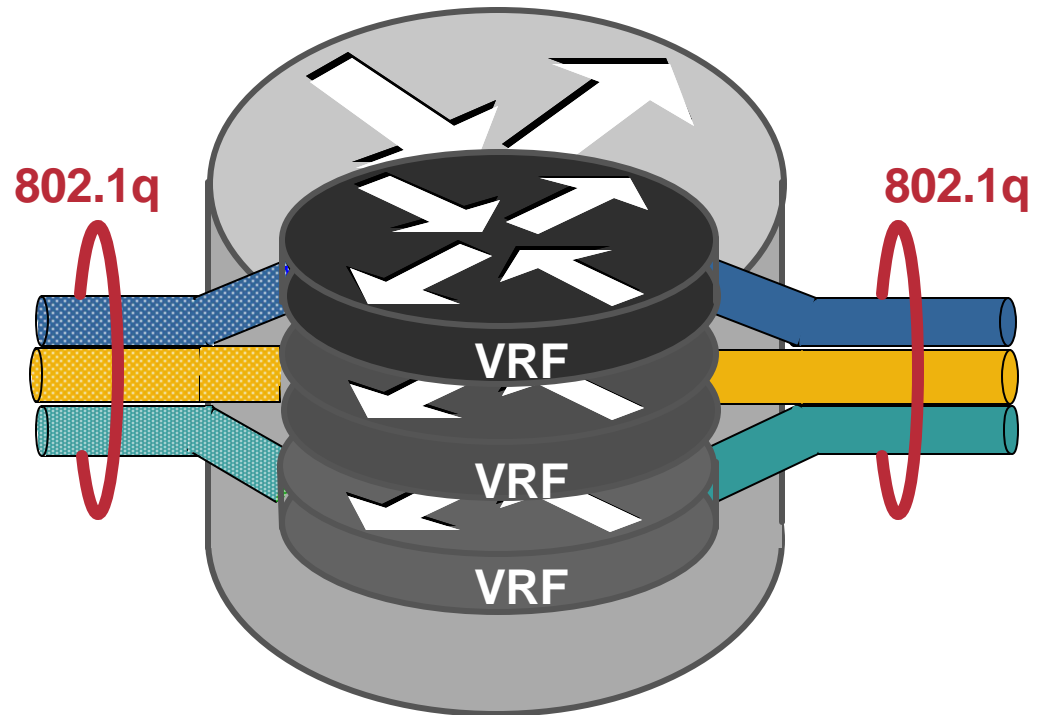

VRF-Lite Supported on
6500, 4500 Sup IV and
Sup V, 3560 and 3750

Segmentation and Virtualization

End to End VRF-Lite

- Configuring distinct Guest and Remediation VRFs allows the network to keep that traffic isolated
- Also can be extended to support other CUGs

```
ip vrf GuestAccess
rd 10:10

interface vlan 10
ip address 10.10.2.4
ip vrf forwarding GuestAccess

interface vlan 110
ip address 10.100.1.4
ip vrf forwarding GuestAccess

router eigrp 200
address-family ipv4 vrf GuestAccess
network 10.0.0.0
no auto-summary
exit-address-family
```

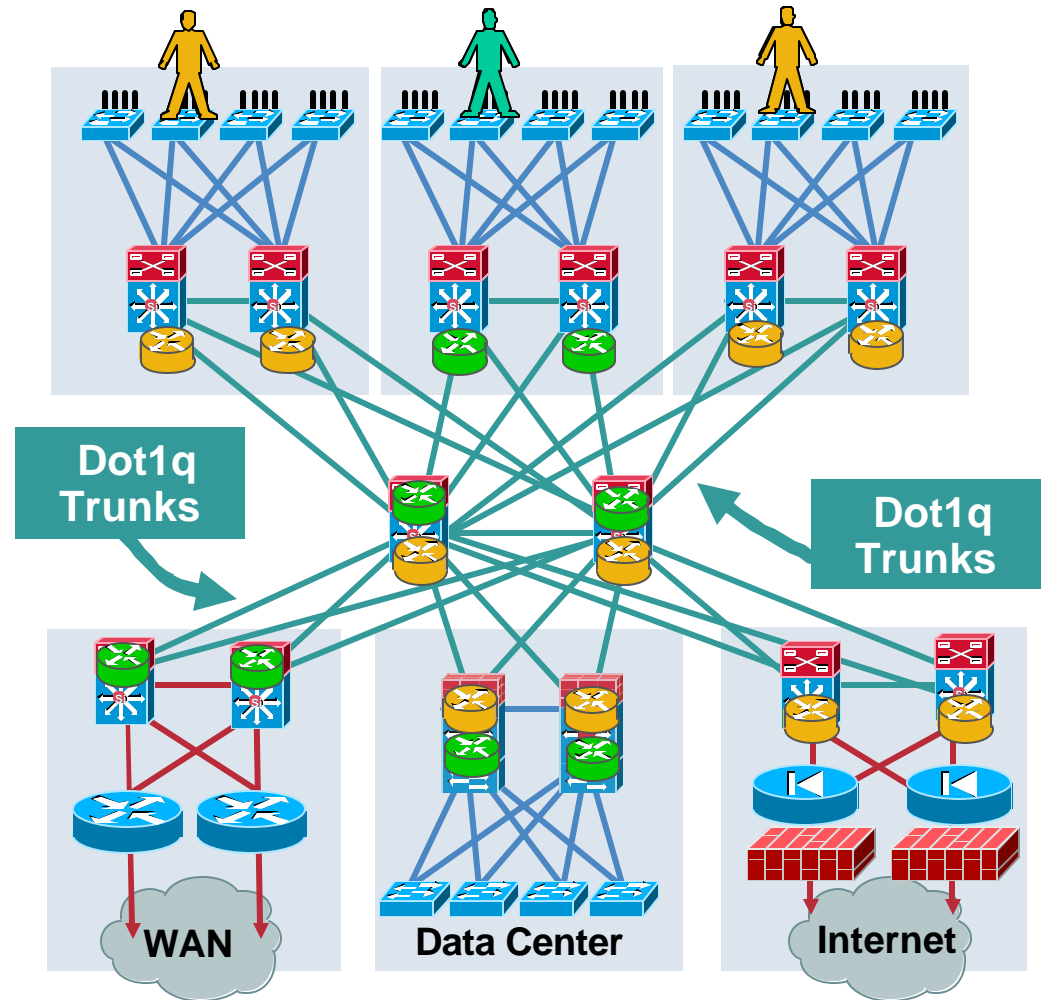

Virtualized Devices and Data Paths

VRF with MPLS Tag Switching

- When the number of Closed User Group's exceeds 3 or the number of hops > 3 then consider using MPLS tag switching as the virtual data path
- No CE, either L2 access or access switch PE
- VPN at the first L3 hop (distribution = PE)
- MP-iBGP at the distribution only (PE)
- MPLS in core and distribution (P and PE)
- Overlaid onto existing IGP

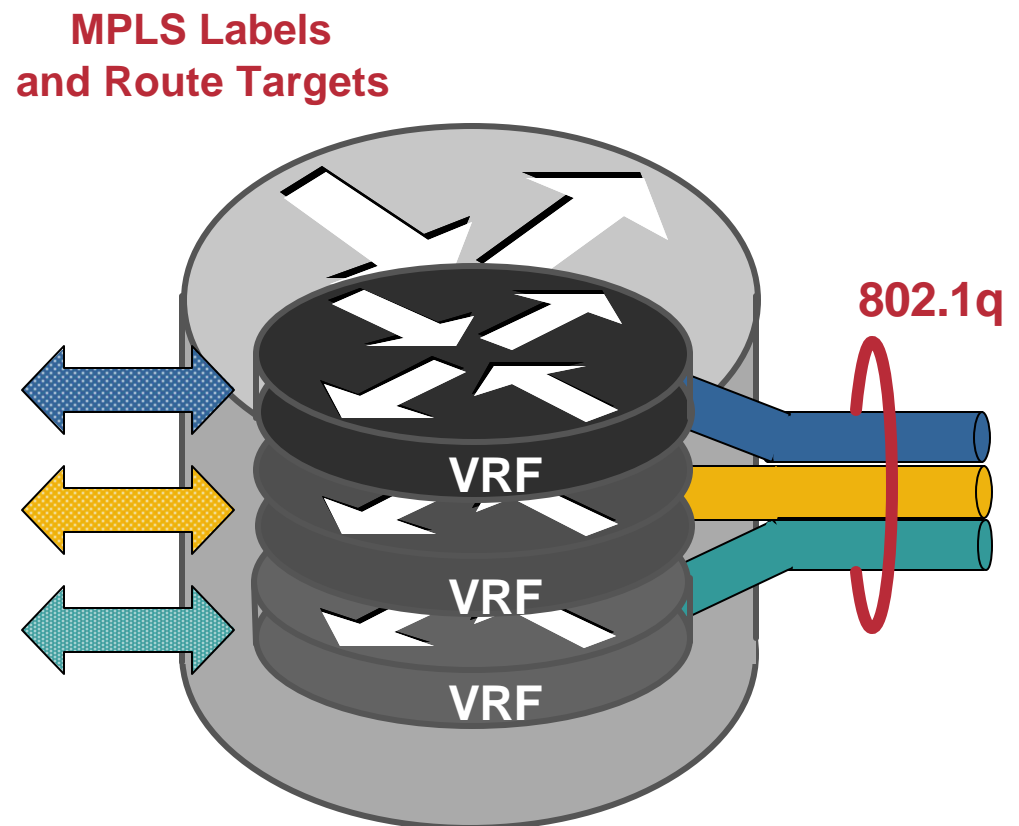

Segmentation and Virtualization

Closed User Group with RFC 2547 VPNs

Cisco.com

- Provides for larger full meshed any-to-any connectivity within each Closed User Group

```

ip vrf Red
 rd 100:33
 route-target both 100:33

interface FastEthernet0/0
 ip address 10.0.0.11 255.255.255.252
 tag-switching ip

interface Vlan11
 ip vrf forwarding Red
 ip address 10.20.4.1/24

router bgp 100
 no bgp default ipv4-unicast
 neighbor 1.1.1.5 remote-as 100
 neighbor 1.1.1.5 update-source Loopback0

 address-family vpnv4
 neighbor 1.1.1.5 activate
 neighbor 1.1.1.5 send-community extended

 address-family ipv4 vrf Red
 network 10.20.4.0 mask 255.255.255.0
    
```

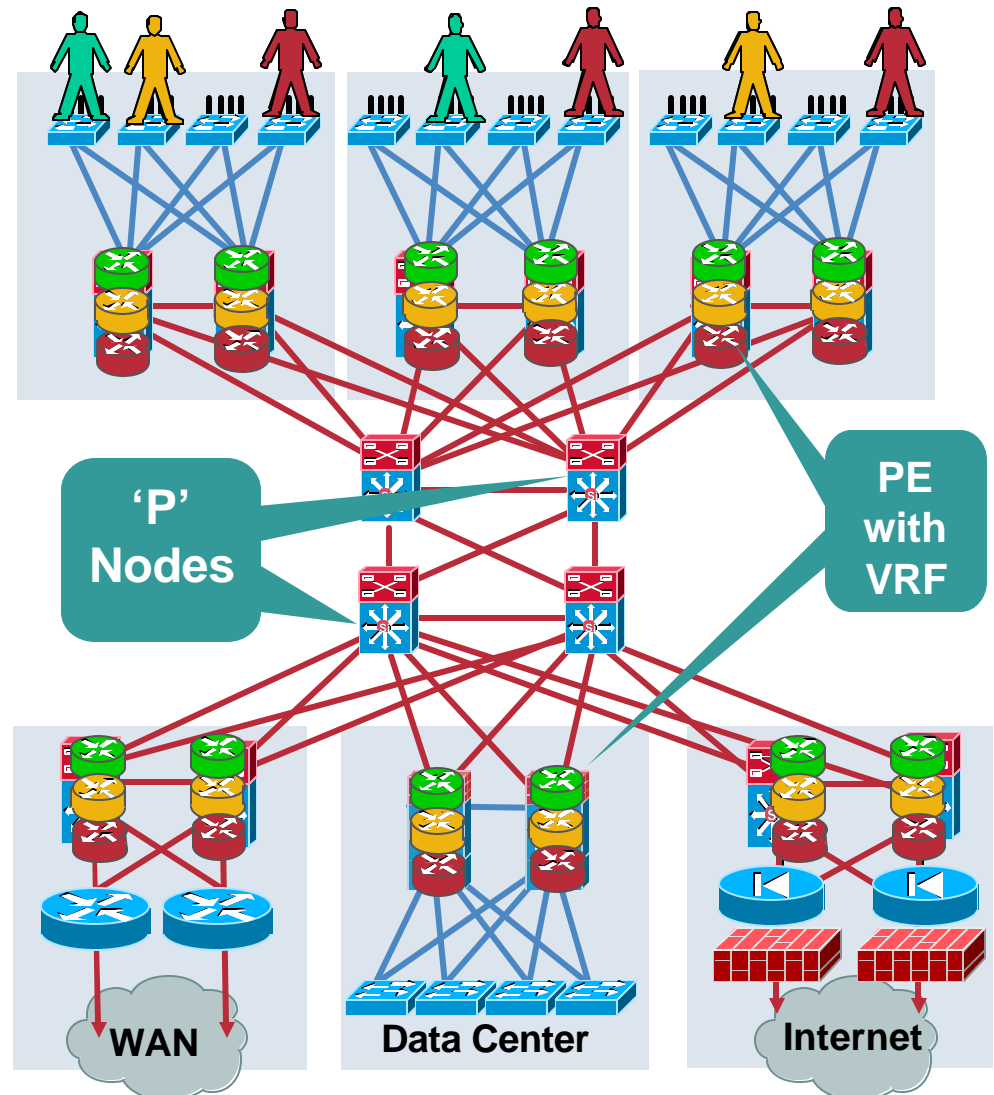

Multilayer Campus Design

Leveraging Advanced Technologies

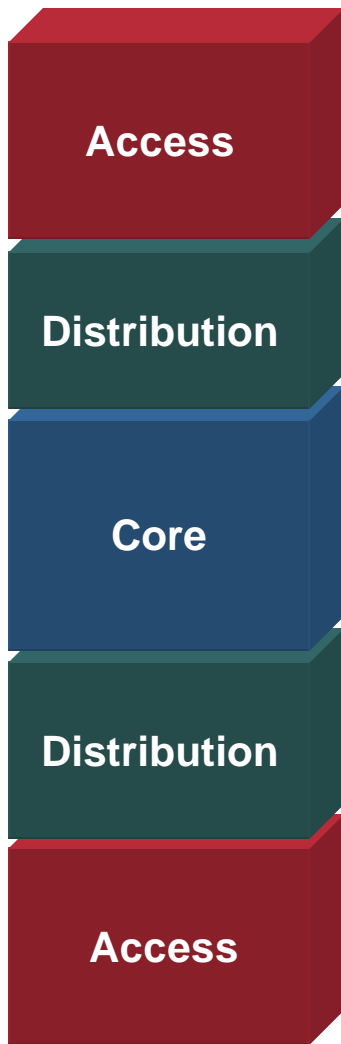

- Hierarchical design is still the rule
- However there are new ways to implement HA within the distribution block
- QoS is a core feature not an option; it both protects and secures
- Wireless roaming is now possible to do in your structured design
- However wireless and 802.1x are creating the need for additional VLANs
- Data, voice, wireless mgmt, wireless MCast, guest and quarantine VLANs
- Security is not just ACLs and firewalls it is also about integrated anomaly prevention
- High availability depends on being able to survive the unexpected

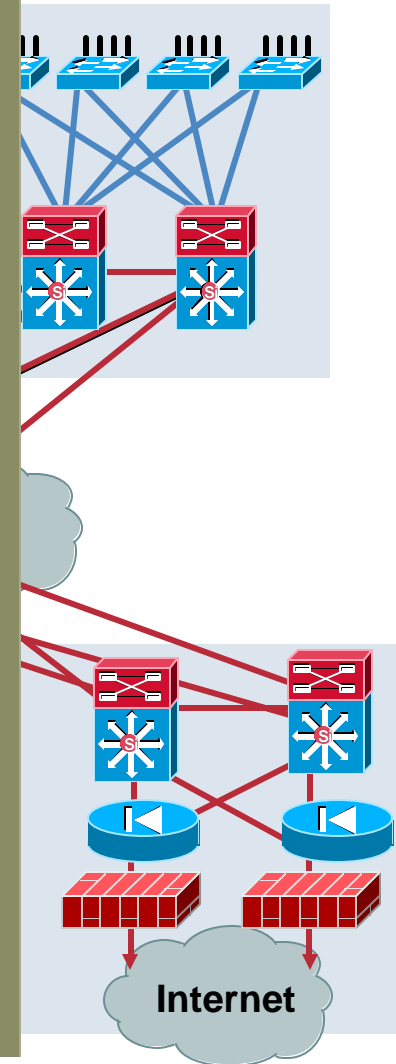

CISCO SYSTEMS

